



Super Sylon Instruction & Parts Manual

Tingue
7009 Cessna Drive
Greensboro, NC 27409
800-222-9954

Super Sylon Instruction & Parts Manual

Table of Contents

		Page
Section I	Safety	1
1.1	Safety Overview	1
1.2	Maintenance And Repair	1
1.3	Safety Features	1
1.3.1	Main Disconnect Switch	1
1.3.2	Safety Stop Buttons	1
1.3.3	Safety Guards	2
1.3.4	Safety Labels	2
1.3.5	Safety Messages in this manual	2
Section II	Introduction And Description	3
2.1	General Description	3
2.2	Principles Of Operation	3
2.3	Ironer Specifications	4
Section III	Operation	5
3.1	Operating Instructions	5
3.2	Inverter Cabinet Operating Controls	5
3.2.1	Disconnect Switch	5
3.2.2	Emergency Stop	5
3.2.3	Stop Button	5
3.2.4	Start Button	5
3.2.5	Wax Mode Selector Switch and Vacuum Motor Auto/Off Switch	5
3.2.6	Drive Motor Speed Control Switch	6
3.2.7	Raise/Lower Switch	6
3.2.8	Forward/Reverse Switch and Reverse Jog Switch	6
3.2.9	Tachometer	6
3.3	Daily Pre-Operating Procedure	6
3.3.1	Heating the Chests	6
3.3.2	Starting the Ironer	7
3.3.3	Cleaning the Ironer Chests	7
3.3.4	Waxing the Chests	8
3.4	Post Operating Procedures	8
Section IV	Maintenance	
4.1	Periodic Inspections and Servicing	9
4.2	Lubrication	10
4.3	Replacing Clipper Lace Aprons	12
4.4	Apron Adjustment	12
4.5	Apron Guide Roll Installation	14
4.6	Raise/Lower Limit Switch Adjustment	15
4.7	Setting the Pressure Screws	16
Section V	Trouble Shooting	17

Section VI	Illustrated Parts	
Illustration 1	Right Hand side Outside Elevation	18
Illustration 2	Left Hand side Outside Elevation	21
Illustration 3	Right Hand side Inside Elevation	23
Illustration 4	Left Hand side Inside Elevation	26
Illustration 5	Typical Right Hand Front End Side Elevation	28
Illustration 6	Typical Left Hand Front End Side Elevation	31
Illustration 7	Typical Right Hand Delivery End Side Elevation	34
Illustration 8	Typical Inside Section Front End	37
Illustration 9	Typical Inside Section Delivery End	39
Illustration 10	Section of Clutch and Drive Sheave (NA Tingue Remanufactured Ironer)	41
Illustration 11	Padded Roll	43
Illustration 13	Roll Raising Transmission	46
Illustration 14	Miscellaneous Parts	48
Illustration 15	Guide Roll Box Assemblies	50
Illustration 17	Tape Device	53
Illustration 18	Vacuum System	55
Section VII	Electrical	
Illustration 19	230 Volt 10HP Right Hand Drive Conversion Electrical Diagram	57
Illustration 20	230 Volt 10HP Right Hand Drive Conversion w/2HP Vacuum Electrical Diagram	59
Illustration 21	460 Volt 10HP Right Hand Drive Conversion Electrical Diagram	60
Illustration 22	460 Volt 10HP Right Hand Drive Conversion w/2HP Vacuum Electrical Diagram	61
	Tingue Machine Settings for ACS 550 Drive	62

Super Sylon Instruction & Parts Manual

List of Tables

2-1	Overall Dimension	4
2-2	Steam Requirements	4
2-3	Motor and Drive Specifications	4
2-4	Electrical Specifications 460 Volt Cabinet	4
2-5	Electrical Specifications 230 Volt Cabinet	4
4-1	Periodic Inspections and Servicing	9
4-2	Lubrication Chart	10
4-2	Apron Installation	11
4-3	Apron Sizes	12
5-1	Troubleshooting	17

List of Figures

Figure 3.1	Inverter Cabinet Controls	5
Figure 4.1	Lubrication Points	10
Figure 4.2	Apron Installation	11
Figure 4.3	Apron Control Device	13
Figure 4.4	Apron Tracking Adjustments	14
Figure 4.5	Apron Guide Roll Installation	15
Figure 4.6	Raise/Lower Limit Switch Adjustments	15
Figure 4.7	Pressure Screws	16

WARNING

It is the responsibility of the purchaser of this machinery to train their operating personnel in the safe and proper operation of this machinery.

It is furthermore understood that Tingue assumes no responsibility for injury, disability or death resulting from improper operation of, or removal from, or bypassing thereof, any electrical or mechanical safety devices or designs of this machinery.

Section 1

Safety

1.1 Safety Overview

Safe operation and maintenance of the ironer must be the first priority of all supervisors, operators, and maintenance personnel. Safety begins with safe work practices

Keep hands and clothing away from the moving parts of the ironer while it is operating. Always turn off the ironer and use proper “Lock-out/Tag-out” procedures when clearing a jam.

Operate the ironer only with all guards in place and all safety features operating correctly. Never operate the ironer with any safety features bypassed.

Do not pull on the finished flatwork while it is still in the machine. Take the flatwork only after it has cleared the ironer.

1.2 Maintenance and Repair

WARNING

Always use extreme caution when performing any repairs on the ironer. Ironer surfaces can be extremely hot.

Know and utilize the proper procedure for locking out and tagging equipment during repair procedures. Failure to do so could result in serious injury.

Only qualified personnel should troubleshoot and repair this unit.

Before attempting any repair work, review these safety steps and precautions to protect yourself and the machine.

Your site should have procedures that comply with government regulations and standards for equipment lockout/tagout during maintenance and repair. Ask your supervisor for specific information. It is the users’ responsibility to make sure they comply with all safety procedures.

1.3 Safety Features

WARNING

Never bypass any of the safety devices. This could result in serious injury.

There are several categories of safety features:

- Main Disconnect Switch
- Safety Stop Buttons
- Safety Guards
- Safety Labels
- Safety Messages in this Manual

1.3.1 Main Disconnect Switch

The Main Disconnect switch is located on the outside of the inverter cabinet. When turned to OFF, this switch shuts off incoming electrical power to the unit. The Main Disconnect switch is designed to allow for locking the disconnect switch in the off position. Lock the main disconnect switch in the OFF position before performing any maintenance or repair work.

WARNING

Only a qualified electrician should open or perform any maintenance inside the inverter cabinet or motor electrical connection boxes. Read and follow all safety requirements listed in the ABB inverter operating manual provided with this ironer.

1.3.2 Safety Stop Buttons

Pressing red Emergency Stop button will immediately stop the ironer. The emergency stop button must be pulled back out in order to restart the machine.

The preferred method of stopping the operation of the unit is by pressing the red Stop button located on top slanted portion of the inverter cabinet.

1.3.3 Safety Guards

A red safety finger guard runs the entire length of the unit's working area and physically restricts hands from coming into contact with ironer rolls.

WARNING

Operate the ironer only with all guards in place

1.3.4 Safety Labels

WARNING and CAUTION labels are placed at locations around the ironer to keep operators and maintenance personnel alert in particular areas.

WARNING messages alert personnel that injury may result from not following recommended procedures.

CAUTION labels alert personnel the machine may be damaged if conditions, practices, or procedures are not observed.

When training operators, take the time to locate, review, and understand all areas where labels are posted.

***NOTE:** Do not remove safety labels at any time. If a label needs to be replaced, contact Tingue for free replacements.*

1.3.5 Safety Messages in this Manual

WARNING and CAUTION messages also appear in this manual to highlight essential safety information.

WARNING messages alert personnel that **personal injury may result** from not following recommended procedures.

Notes, cautions and warnings are used throughout the manual to emphasize important and critical instructions.

NOTE

A note is used to emphasize a specific function or fact pertinent to the efficient operation of the ironer.

CAUTION

A caution indicates and explains that unless the procedure outlined is followed, damage to the unit may result.

WARNING

Warning indicates and explains that unless the procedure outlined is followed, personal injury may result.

Section II

Introduction and Description

2.1 General Description

The Remanufactured American Super Sylon is built to give you years of top quality work at a high production rate. The simplicity of design greatly cuts maintenance costs yet allows for dependable and efficient service.

Structurally, the ironer consists of two frames held rigidly together by heavy steel tie rods. Each frame is a one piece Meehanite metal casting. Guards enclose the frame and driving mechanism.

The chests in the ironer are also Meehanite metal castings. Each chest has a highly polished top and bottom surface and is designed for 125 PSI steam pressure for increased drying capacity.

The pressing rolls are made of seamless, forge-steel tubes with two transmitter plates and one gudgeon welded into the end of each roll. The rolls are either hard rolls or have 12.7 MM springs installed with vacuum exhaust attachments.

The ironer comes equipped with controlled roll pressure which allows for higher quality finishing for all types of flatwork. Tingue remanufactured ironer comes equipped with a motor operating roll lifting system with limit switches to prevent over pressuring the rolls.

All the gears are on the right side of the ironer. Tingue Remanufactured ironers come with a drive motor and gearbox that are also located on the right side of the ironer. The gearbox drives a sprocket attached to an 80 tooth gear that drives a train of other 80 tooth gears that are alternately compounded with a 12 tooth sprocket. Each 12 tooth sprocket drives sprockets on two padded rolls through a separate roller chain.

A finger guard extends the full length of the ironer over the ribbon feed. It is connected to the inverter safety circuit of the ironer so that a touch of the operator's hands causes the ironer to stop.

There are two canvas aprons located under the chests. These aprons carry the flatwork under the chests and back to the delivery end of the ironer. The tension on the aprons can be adjusted by means of a hand crank on each of the two tension brackets mounted on each side of the delivery end of the ironer.

A series on continuous tapes travels from spools (positioned over #1 roll) between each chest and padded roll to the delivery end of the ironer. There they pass around a tape bar and over the padded rolls back to the spools. The purpose of these tapes is to keep the flatwork from becoming wound around the padded rolls.

The Tingue remanufactured ironer comes equipped with an inverter drive mounted in a cabinet at the left or right front of the ironer. A digital readout on the cabinet indicated the ironer speed in feet per minute.

2.2 Principle of Operation

The ironer is designed for speeds up to 115 feet per minute. This is dependent on several things.

1. The type of the work to be finished.
2. The speed at which the operators are able to feed the work into the ironer.
3. The moisture content of the work being finished.

When the chests have been properly heated the flatwork is placed on the feed table perpendicular to the feed ribbons or fed into the ironer via a feeder placed in front of the ironer. The work passes under a doffer roll which keeps the work flat and taut as it is pulled over the #1 chest by the #1 roll.

Each chest is slightly higher on the side towards the delivery end of the ironer to allow free passage of the work from one chest to the next.

The flatwork is slowly dried and finished as it passes over each chest. As it leaves the last chest the upper apron pulls it under the chest and each

chest in succession to the feed end of the ironer. This pass puts the final touch on the high quality finish of the flatwork.

The direction of the flatwork is reversed by the lower apron at the feed end of the ironer. It is now carried to the delivery end of the ironer where it passes between two apron guide rolls and exits the ironer.

2.3 Ironer Specifications

Following are tables showing the various specifications needed for ironer installation.

Table 2-1 Overall Dimensions

120" 8 Roll Super Sylon

Width	167"
Length	180"
Weight	33,000

Table 2-2 Steam Requirements

Steam Connection	2"
Condensate Connection	2"
Max Steam Pressure	125 PSI
Min Steam Pressure	100 PSI
Steam Consumption	960 lbs/hr 27.8 BPH

Table 2-3 Motor and Drive Specifications

Speed Range	0-115 FPM
Drive Motor	10 HP
Vacuum Motor	1 HP
Raising Rig Motor	1 HP

Table 2-4 Electrical Specifications
460 Volt Cabinet

Volts	460 VAC	Largest Motor FLA	12.5 AMPS
Phase	3	SCCR-KA rms:	10 KA
Hertz	60	@ Maximum Volts	460 VAC
Panel FLA	49.42		

Fuse	Amp	Volt	Type
F1, F2, F3	20	600	JJS-20
F10, F11	3	600	FNQR-3
F12, F13	1	600	FNM-1
F31, F32, F33	20	600	FNQR-20
F41, F42, F43	20	600	FNQR-20

Table 2-5 Electrical Specifications
230 Volt Cabinet

Volts	230 VAC	Largest Motor FLA	25 AMPS
Phase	3	SCCR-KA rms:	10 KA
Hertz	60	@ Maximum Volts	230 VAC
Panel FLA	68.85		

Fuse	Amp	Volt	Type
F1, F2, F3	40	600	JJS-40
F10, F11	3	600	FNQR-3
F12, F13	1	600	FNM-1
F31, F32, F33	20	600	FNQR-20
F41, F42, F43	20	600	FNQR-20

Section III Operation

3.1 Operating Instructions

The operational design of the Super Sylon Ironer is quite simple. The drive motor is started and stopped using the controls located on the upper slanted section of the inverter cabinet. The ironer can be adjusted to the proper finishing speed for all types of flatwork. The speed is registered on the tachometer and reads out in feet per minute.

Figure 3.1 Inverter Cabinet Controls

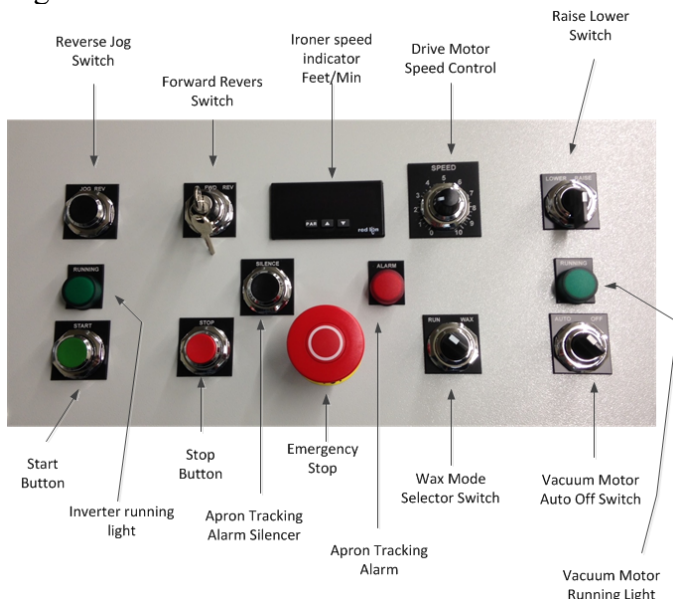

3.2 Inverter Cabinet Operating Controls

3.2.1 Disconnect Switch

The disconnect switch is located on the front of the inverter cabinet. Turning the switch to ON energizes the cabinet. Turning the switch to OFF de-energizes the inverter cabinet and provides a place to install a Lock Out/Tag Out.

3.2.2 Emergency Stop

Pressing the Emergency Stop button will stop the machine. Once the Emergency Stop button is pushed it will remain in the Emergency Stop position and must be pulled back out to re-start the

ironer. Additionally, pressing the red Finger Guard on the ironer will also immediately stop the ironer.

NOTE

Inverter cabinet's Emergency Stop circuit has the ability to be connected in series with the Folder if attached. This will cause the ironer to stop if an E-Stop on the folder is activated or if the folder is turned off. When using this circuit, the folder must be started before starting the ironer.

NOTE

Inverter cabinet's circuitry also allows for connection to the Feeders Emergency Stop circuit. This will cause the Feeder to stop if the ironer is stopped.

3.2.3 Stop Button

Pressing the stop button will stop the ironer but not as rapidly as the Emergency Stop button will and should be used to normally stop the ironer.

3.2.4 Start Button

Pressing the start button will start the ironer as long as all the Emergency Stop switches are reset. Pressing the start button will illuminate the green light above the start switch. This is a visual indication the inverter is running even if the Drive Motor Speed Control is reduced to zero.

3.2.5 Wax Mode Selector Switch and Vacuum Motor Auto/Off Switch

The Wax Mode Selector Switch has two positions Run and Wax and works in conjunction with the Vacuum Motor Auto/Off Switch.

With the Wax Mode Selector Switch in Run the drive motor will operate at the speed selected by the Drive Motor Speed Control Switch.

When the Wax Mode Selector Switch is taken to Wax it will slow the ironer down to the proper waxing speed.

The Vacuum Motor Auto/Off Switch works in conjunction with the Wax Mode Selector Switch. With the Wax Mode Selector Switch in Run and the Vacuum Motor Auto/Off Switch in Auto the vacuum will run. Taking the Wax Mode Selector Switch to Wax or the Vacuum Motor Auto/Off Switch to Off will stop the vacuum motor.

When the vacuum motor is running the green indicating light above the Vacuum Motor Auto/Off Switch will illuminate.

3.2.6 Drive Motor Speed Control Switch

When the motor is running in the Run mode the ironer speed is controlled by the Drive Motor Speed Control Switch. Turning the switch clockwise will increase the speed. Turning the switch counter clockwise will decrease the speed.

3.2.7 Raise/Lower Switch

CAUTION

When lowering the rolls, never allow the front pressure bar keyway to travel past the 6 o'clock position. This may cause the ironer to jump out of time and damage to the ironer may occur.

When raising the rolls, never allow the front pressure bar keyway to travel past the 12 o'clock position. This may cause the ironer to jump out of time and damage to the ironer may occur.

NOTE

It will be necessary for maintenance personnel to adjust the lower limit stop switch as the ironer roll pads wear to ensure proper roll pressure.

The raise/lower switch is used to take pressure on an off the ironer using the motorized raise/lower rig. The switch works in conjunction with the raise/lower limit switches. Turning the switch to lower will lower the rolls and put pressure on the ironer until the lower limit switch is contacted.

Turning the switch to raise will raise the rolls and take pressure off the ironer until the raise switch is contacted.

3.2.8 Forward/Reverse Switch and Reverse Jog Switch

CAUTION

Operating the ironer in the reverse direction should only be performed by qualified personnel. Operating the ironer in the reverse direction can cause damage to pads, covers, fingers and other components of the ironer.

With the Forward/Reverse Switch in Forward the ironer will operate normally. To operate the ironer in the reverse direction, take the Forward Reverse Key Switch to Reverse and press in the Reverse Jog Switch. The ironer will run in reverse only while the Reverse Jog Switch is held in. When jogging in reverse the ironer will run at the speed selected on the Drive Motor Speed Control Switch.

3.2.9 Tachometer

The tachometer reads out in feet per minute and measures the speed of the first roll. The tachometer will not indicate at speeds below 30 feet per minute.

3.3 Daily Pre-Operating Procedure

Before each days operation of the ironer there are definite procedures that must be followed:

3.3.1 Heating the chests

The padding, chest surfaces may be damaged and the gears, sprockets and chains will be subjected to unnecessary strain if the chests are not thoroughly heated before starting the ironer. This is accomplished by the following steps:

1. Open the condensate return valve.
2. Open the bypass line, if equipped around the steam supply valve. If the steam supply valve is not equipped with a bypass valve crack the steam supply valve to gradually heat up the chests to operating temperature.
3. After 30 to 45 minutes the steam supply valve may be fully opened and the bypass valve shut.

3.3.2 Starting the ironer

WARNING

Before starting the ironer ensure that all guards are in place and that there is nothing interfering with the rolls or feed belts.

1. Energize the inverter cabinet by shutting the disconnect switch located on the front of the inverter cabinet.
2. Lower the rolls until the lower limit switch stops the raising rig motor or until the front pressure bar keyway reaches the 6 o'clock position.

CAUTION

Never allow the front pressure bar keyway to travel past the 6 o'clock position. This may cause the ironer to jump out of time and damage to the ironer may occur.

When raising the rolls, never allow the front pressure bar keyway to travel past the 12 o'clock position. This may cause the ironer to jump out of time and damage to the ironer may occur.

NOTE

It will be necessary for maintenance personnel to adjust the lower limit stop switch as the ironer roll pads wear to ensure proper roll pressure. See paragraph 4.6

3. Place the Wax Mode Selector switch in Wax and the Vacuum motor Switch in Auto.

CAUTION

At any time during the operation of the ironer it becomes necessary to immediately stop the ironer. Press the Emergency Stop button on the inverter cabinet or push the finger guard. Either of these methods will activate the emergency stop circuit in the inverter.

Normal stopping of the ironer can be accomplished by pressing the red stop button

4. Start the ironer by pressing the Start button on the inverter cabinet.

WARNING

When the ironer is started for the first time each day test the Finger Guard Safety switch by pushing the Finger Guard and ensuring the ironer stops.

3.3.3 Cleaning the ironer chests

NOTE

It is essential that the ironer surfaces of the chests present as little impedance to the flow of flatwork as possible. This will help assure quality work quality work at the maximum production rate.

NOTE

Build up of residue on the ironer chests, especially on the leading and trailing edges and the exposed area between the first two or three rolls, contributes to poor edge to edge ironing as well as to the rolling of the flatwork on the ironer. Some causes of build-up are poor rinsing, excessive use of starch, and the use of extremely hard water.

CAUTION

If an automatic folding machine is installed behind the ironer turn off the static bar and set the folder in the bypass position before running the cleaning cloth to prevent a jam or possible fire.

CAUTION

The cleaning cloth will be extremely hot when it exist the ironer. Use insulated gloves when handling the cleaning cloth.

1. Using two people run the Tingle cleaning cloth through the ironer twice once on the left and once on the right.

NOTE

Chests should be inspected frequently for residual buildup. Any build up should be removed with a putty knife, scraper, fine abrasive paper or cloth or by use of a Tingle Continuous Cleaning Cloth.

When cleaning the chests care must be taken not to mar the chests. Cleaning must always be followed with the application of a wax.

3.3.4 Waxing the chests

CAUTION

If an automatic folding machine is installed behind the ironer turn off the static bar and set the folder in the bypass position before waxing to prevent a jam or possible fire.

1. Ensure the Wax Mode selector switch is in the wax position.

CAUTION

If an automatic folding machine is installed behind the ironer turn off the static bar and set the folder in the bypass position before running the wax cloth to prevent a jam or possible fire.

NOTE

Contact your local Tingle Representative or check the instructions on your wax to determine the proper amount of wax to use when waxing your ironer.

CAUTION

The wax cloth will be extremely hot when it exist the ironer. Use insulated gloves when handling the wax cloth.

2. Using two people run the Tingle Wax Cloth with wax flap through the ironer two times. Once from the left and once from the right.
3. When the waxing procedure is complete. Place the Wax Mode Selector Switch in the Run position and take the Drive Motor Speed Control switch to the desired ironer speed.

NOTE

The wax procedure should be repeated every two hours of operation.

3.4 Post Operating Instructions

Perform the following operations at daily shutdown or when the ironer will be idle for an extended period:

CAUTION

Make sure all the linen has exited the ironer before stopping the ironer. Linen left in the ironer can damage the linen or possibly cause fire.

1. Turn the Drive Motor Speed Control Switch to lower the ironer speed to approximately 30 feet per minute.

CAUTION

When raising the rolls, never allow the front pressure bar keyway to travel past the 12 o'clock position. This may cause the ironer to jump out of time and damage to the ironer may occur.

2. Take pressure off the ironer by taking the Raise/Lower switch to raise until the upper limit switch stops the raising motor.
3. Depress the Stop button on the inverter cabinet.
4. Open the Disconnect Switch on the front of the inverter cabinet.
5. Shut the steam supply valve.

Section IV Maintenance

4.1 Periodic Inspections and Servicing

Table 4-1 lists the inspections and adjustments to be performed at periodic intervals.

TABLE 4-1 PERIODIC INSPECTIONS AND SERVICING

TIME INTERVAL	OPERATION OR INSPECTION
Daily	Heat up ironer and lower rolls until roll box pins spin freely
	Clean & Lubricate Chests
	Press Safety Board and verify ironer will stop within 6 inches of travel
	Replace any missing Guide Tapes
	Check for any missing Feed Belts
	Check for proper Apron Tension
	Lubricate the ironer as specified in the Lubrication Chart 4-2.
	At the end of the day lift the rolls out of the chest and stop the ironer
Weekly	Blow down the ironer to remove lint
	Disconnect power to Inverter Cabinet, open cover and blow lint from inside inverter cabinet. Blow downward through inverter heat sink to remove lint from the cooling fans at the bottom of the inverter.
	Lubricate ALL Grease Fittings. (Roll Boxes and Intermediate Shafts should be greased at least TWICE per week.
	Check ironer for any steam or air leaks.
	Inspect Pads and Covers for wear.
	Check Feed Belts for proper tension and adjust as necessary.
	Lubricate the ironer as specified in the Lubrication Chart 4-2.
	Check Vacuum for proper operation
	Check that all nuts, bolts and screws are secure
Check for accumulation of dust, dirt, lint and residue on chests and clean as necessary	
Monthly	Remove side covers and clean lint form sides of machine
	Check chain tension and adjust tension as necessary.
	Check Sprocket and Gear Set Screws for tightness
	Check Chest Temperatures
	Check Guide Tape tensioning arms for proper operation.
	Clean Ironer Chest
Quarterly	Check Steam Traps for proper operation
Semi-Annual	Remove the Feed Board and clean the leading edge of the ironer.
	Check Fingers for wear
Annual	Remove and clean vacuum and roll ends

4.2 Lubrication

The Lubrication Chart details, frequency, lubrication points, procedures and recommended lubricants.

Fittings should be wiped clean to avoid injecting dirt with the grease or oil. Keep the grease or oil in covered containers to prevent contamination.

TABLE 4-2 LUBRICATION CHART

Frequency	Lubricant Point See Figure 4.1	Procedure	Type Lubricant
Daily	A ₁ Grease Fittings	Wipe fittings clean; apply grease until pressure until fresh grease appears around bearing/bushing. Wipe grease fitting clean. Wipe up excessive grease around bearing/bushing	Tingue Grease PN: 1210-BA-CASE
Weekly	A Grease Fittings	Wipe fittings clean; apply grease until pressure until fresh grease appears around bearing/bushing. Wipe grease fitting clean. Wipe up excessive grease around bearing/bushing	Tingue Grease PN: 1210-BA-CASE
	B Oil Holes	Add a few drops of oil	Light weight motor or Hydraulic oil

Figure 4.1 Lubrication Points

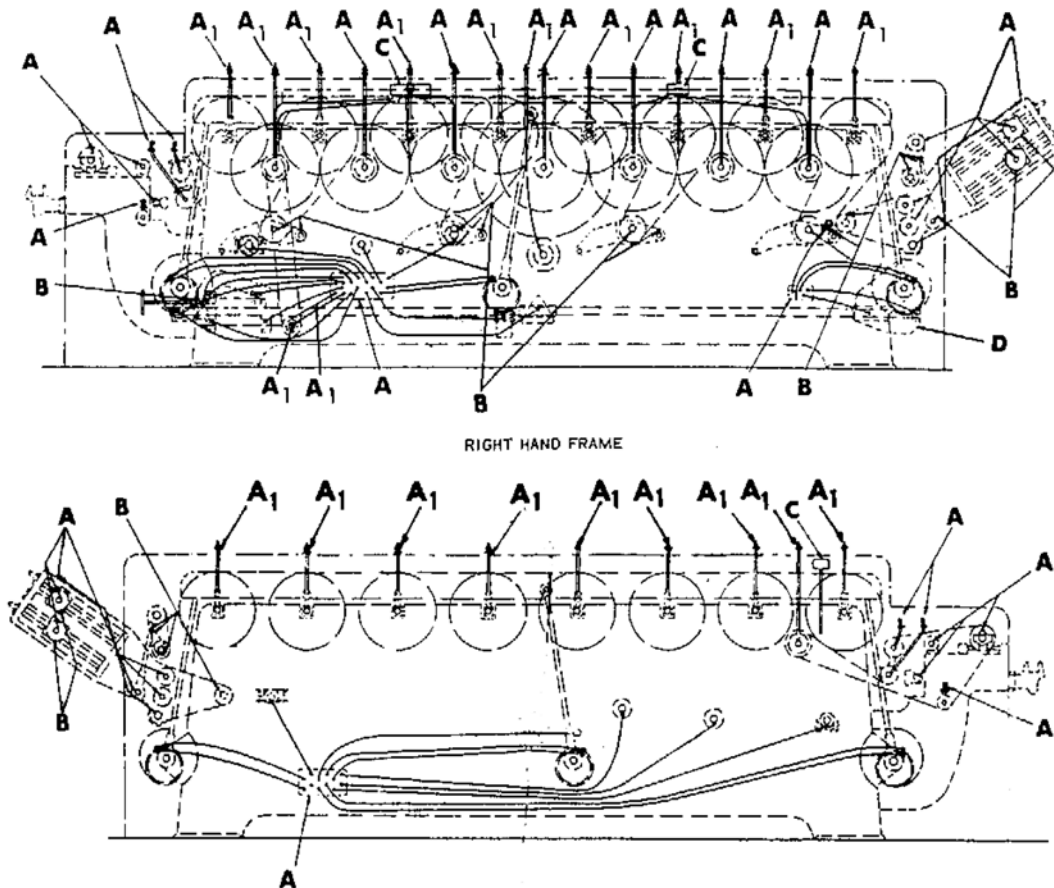

The grease fitting plate locations are for example only. Ironers may have more than one grease fitting plate per side

Figure 4.2 Apron Installation

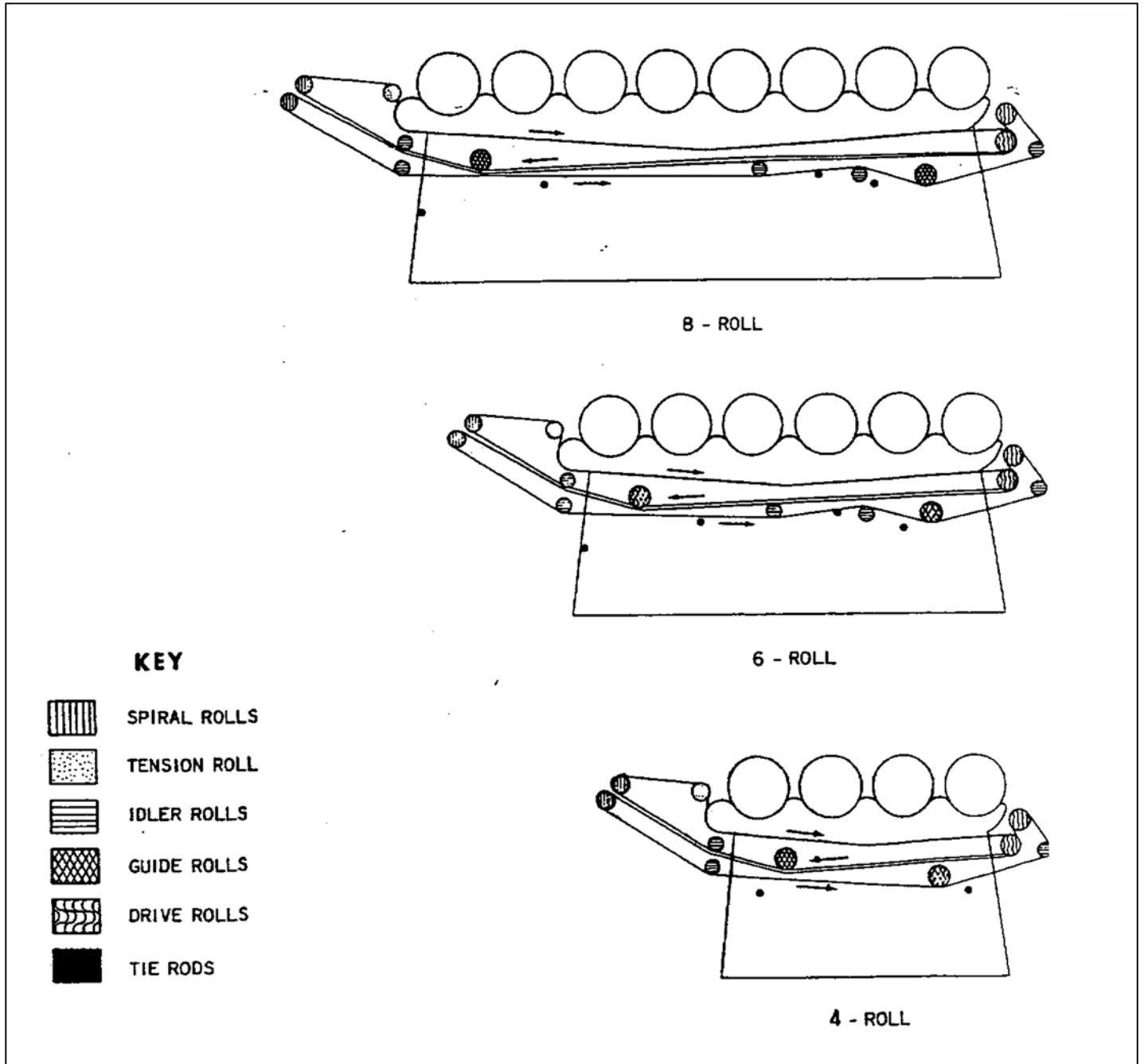

4.3 Replacing Clipper Laced Aprons (see figure 4.2 above).

Perform the following steps to replace the clipper laced apron.

1. Start and run the ironer until the clipper lace for the affected apron reaches the delivery end of the machine.

CAUTION

When raising the rolls, never allow the front pressure bar keyway to travel past the 12 o'clock position. This may cause the ironer to jump out of time and damage to the ironer may occur.

2. Take the pressure completely off the ironer by taking the Raise/Lower switch to raise until the raise limit switch stops the travel.
3. Turn the cranks on the apron tension screws until the blocks bottom in the harps.
4. Remove the clipper lace wire from the old apron.

NOTE

The Tingué clipper lace wire is ground on one end on allow easier insertion into the clipper lace.

5. Attach the new Tingué apron to the old apron by align the clipper lace on the new and old clipper lace and inserting the clipper lace wire.
6. Start the ironer and run at slow speed while guiding the new apron until the leading edge of the new ironer is returned to the delivery end of the ironer.
7. Stop the ironer.
8. Remove the clipper lace wire previously installed between the new and old aprons.
9. Match up the ends of the clipper lace on the new Tingué apron ensuring that the guide lines on the apron match up. Insert a new

Tingué clipper lace wire into the clipper lace.

CAUTION

When lowering the rolls, never allow the front pressure bar keyway to travel past the 6 o'clock position. This may cause the ironer to jump out of time and damage to the ironer may occur.

10. Apply pressure on the ironer by lowering the rolls by taking the Raise/Lower switch to lower until the lower limit switch is contacted.
11. Adjust the cranks on the apron tension screws evenly until the slack is removed from the apron and proper apron tension is obtained.

NOTE

Take care not to put too much tension on the apron to prevent premature failure.

Table 4-3 Apron Sizes

# of Rolls	Model	Apron	Size
6	Super Sylon	Upper	120" x 21' 5"
		Lower	120" x 24' 4"
6	Sylon	Upper	120" x 21' 5"
		Lower	120" x 24' 4"
8	Super Sylon	Upper	120" x 26' 8"
		Lower	120" x 29' 7"
8	Sylon	Upper	120" x 26' 8"
		Lower	120" x 29' 3"

4.4 Apron Adjustment (see figure 4.3 below)

The aprons are automatically guided or controlled by the Automatic Apron Control Device. It consists of guide rolls, a system of connecting rods, bell cranks and counter weights which connect the movable ends of the guide rolls with the corrugated friction spools (Cones) on the spiral rolls.

The principle of operation of the device is best explained by comparing the apron to a conveyor belt. In order for the conveyor belt to travel in a straight line the rollers need to be at right angles to

the belt. If the conveyor belt needs to move right or left one of the friction rolls needs to be adjusted so that it is no longer at a right angle to the belt.

Figure 4.3 Automatic Apron Control Device

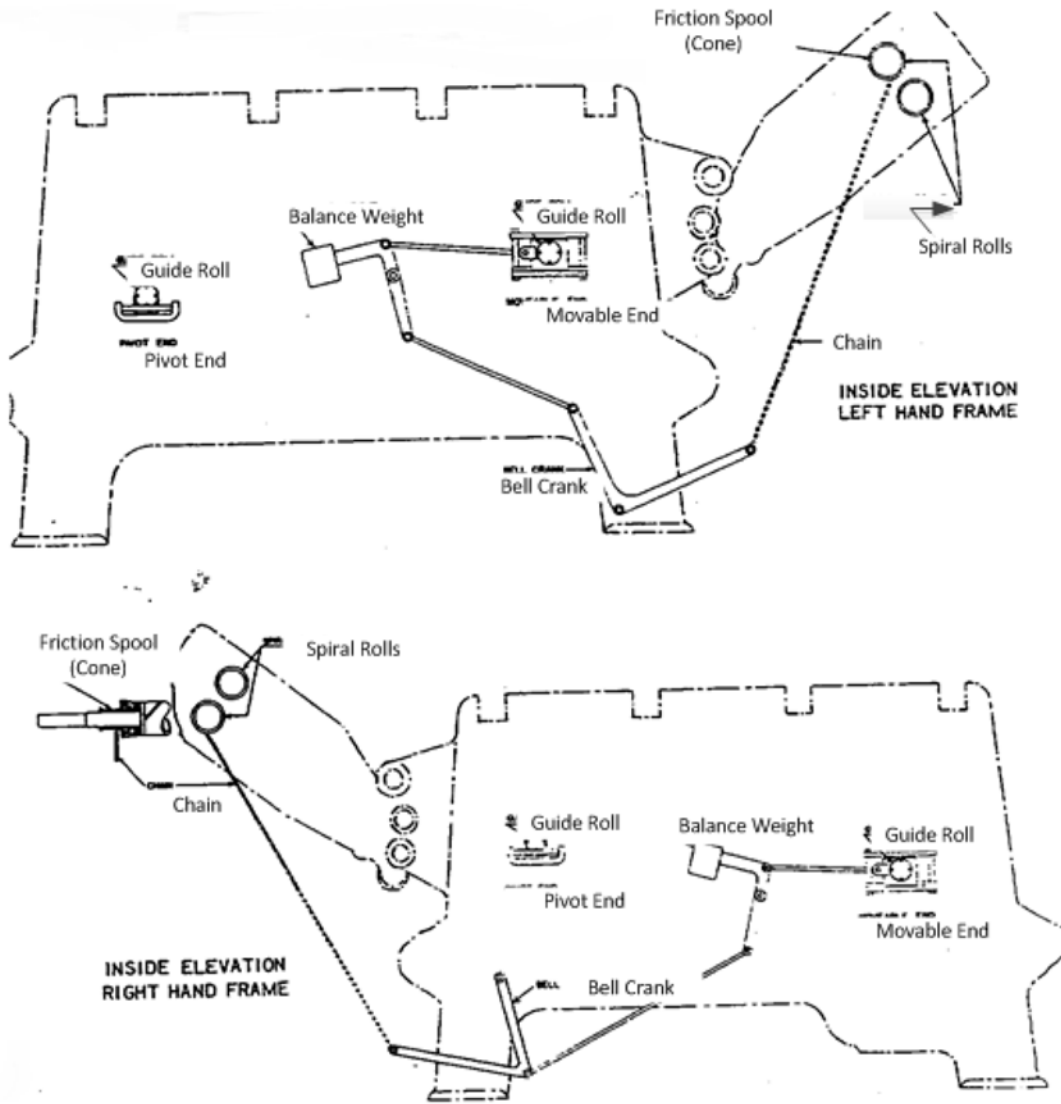

The balance weights should be adjusted so the guide roll travels freely when the aprons run onto the cones. This is important in order to prevent the aprons from having too much weight to lift when the aprons run onto the cones.

If the aprons are tracking to strongly either towards or away from the Cones make the following adjustments: (See figure 4.4 below)

WARNING

Always use extreme caution when performing any repairs on the ironer. Ironer surfaces can be extremely hot.

Know and utilize the proper procedure for locking out and tagging equipment during repair procedures. Failure to do so could result in serious injury.

Only qualified personnel should troubleshoot and repair this unit.

Figure 4.4 Apron Tracking Adjustments

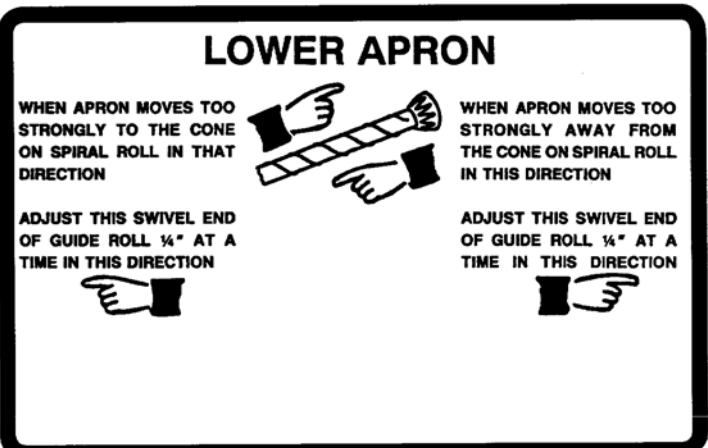
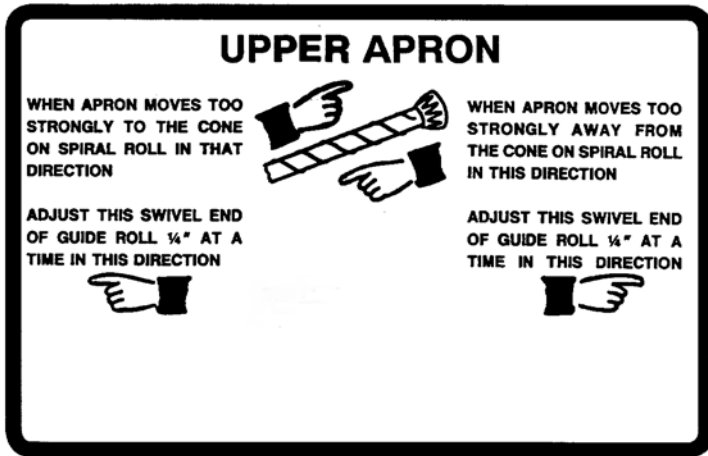

1. Place yourself in a position facing the pivot of the guide roll controlling the faulty apron.
2. Moving the pivot end of the guide roll to the right sends the apron to the Cone side of the Spiral Roll
3. Moving the pivot end of the guide roll to the left sends the apron away from the Cone.

After making the adjustment be sure to tighten the set screw on the pivot end of the guide roll. Make adjustments in 1/4" increments, allowing time for the apron to adjust itself to a new position.

4.5 Apron Guide Roll Installation

Periodically the Apron Guide roll will need to be removed and re-wrapped with a Tingle Apron Drive Roll Cover.

It is important that the Apron Guide Roll be installed with the stepped end of the Guide Roll Shaft inserted into the Movable Guide Box and the opposite end with the trust bearing and collar goes towards the pivot end or stationary guide box.. See figure

Figure 4.5 Apron Gui

Rev 9/29/2015

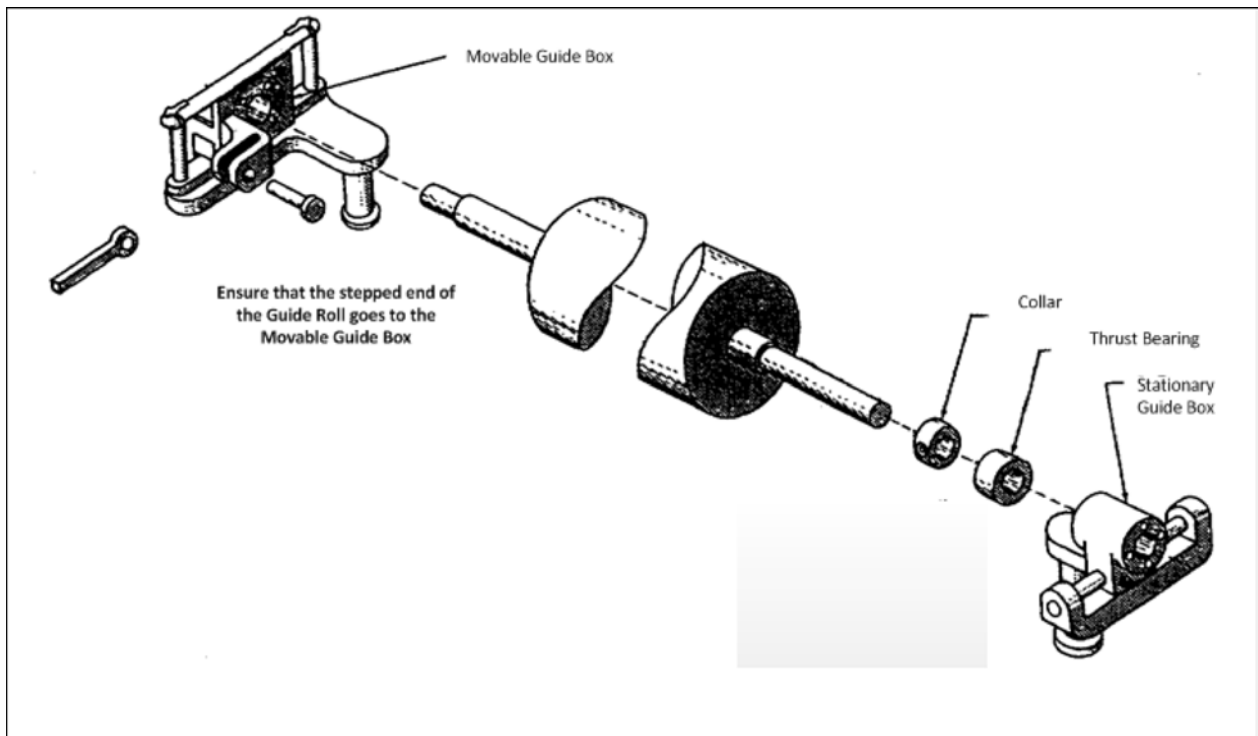
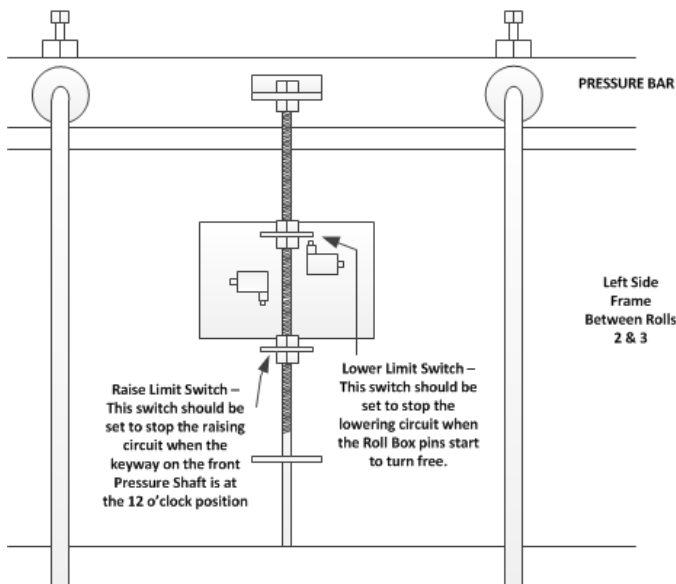

Figure 4.5 Apron Guide Roll

4.6 Raise/Lower Limit Switch Adjustments

Figure 4.6 Raise Lower Limit Switch Adjustments



WARNING

Always use extreme caution when performing any repairs on the ironer. Ironer surfaces can be extremely hot.

Know and utilize the proper procedure for locking out and tagging equipment during repair procedures. Failure to do so could result in serious injury.

Only qualified personnel should troubleshoot and repair this unit.

1. To adjust the lower limit switch apply pressure to the ironer by taking the Raise/Lower Switch to lower until the Roll Box pins turn free.

2. Open the side cover on the left hand side of the ironer and adjust the lower limit switch stop until it make contact with the lower limit switch.
3. To adjust the upper limit switch raise the rolls until the keyway on the front pressure shaft is at the 12 o'clock position.
4. Open the side cover on the left hand side of the ironer and adjust the raise limit switch stop until it makes contact with the upper limit switch.

Figure 4.7 Pressure Screw

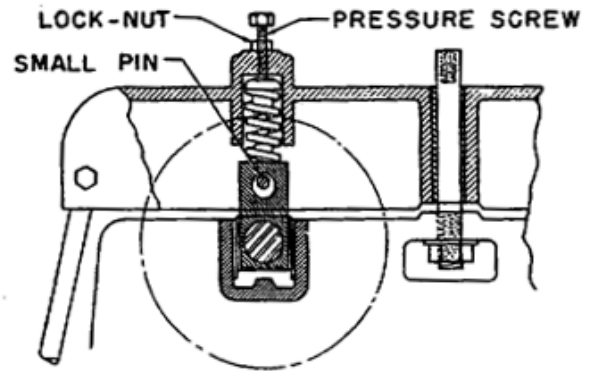

4.7 Setting the Pressure Screws

The procedure for adjusting the pressure screws has changed with the modern Tingue Textiles. The new textiles are weighted to give the proper graduation in roll circumference.

Initially or after a new set of pads and covers are installed adjust the pressure screws as follows:

1. Remove the pressure screws.
2. Clean and lubricate the pressure screws
3. Lower the rolls to apply the proper roll pressure as discussed previously.
4. Install the pressure screws until finger tight and tighten down the locking nut.

If during the operation of the ironer flooding occurs between any of the rolls adjust the roll pressure as follows.

1. Starting with the first roll affected, tighten both the left and right pressure screws the same amount. Generally this should be accomplished in small increments such as 1 or 2 flats (1/6 to 1/3 of a revolution).
2. Allow several hours for the roll padding to compress before making additional adjustments. It may be necessary to adjust the rolls the preceding rolls as well.

Section V Troubleshooting

Symptom	Possible Cause	Remedy
Linens Buckling	Steam chests insufficiently heated	Heat steam chests thoroughly
	Steam chests dirty or insufficiently lubricated	Clean and wax chests
	Improper washroom chemistry or flatwork improperly rinsed	Check washroom chemistry and ensure proper final rinse
	Rolls improperly graduated	Adjust individual roll pressure as described in section para. 4.7.
Linens Sticking to Chests	Steam chests insufficiently heated	Heat steam chests thoroughly
	Steam chests dirty or insufficiently lubricated	Clean and wax chests
	Improper washroom chemistry or flatwork improperly rinsed	Check washroom chemistry and ensure proper final rinse
Ironer Not Delivering Rated Capacity	Poor quality steam (wet or low pressure)	Check steam pressure. Ironer is designed to operate on dry, saturated steam at 125 PSI.
	Steam traps not functioning correctly	Check steam traps for proper operation
	Insufficient extraction	Increase extraction time
	Ironer running too slow	Increase speed of ironer
	Not enough ironer pressure	Increase ironer roll pressure
	Aprons too slack	Tighten aprons
	Flatwork improperly fed into ironer	Have workers increase feed rate to minimize the gap between flatwork pieces.
Aprons will not track properly	Apron guide roll mechanism not functioning properly	Check guide rolls to see that they are traveling freely in their bearings. Verify movable ends of guide rolls move freely when the bell crank chain is pulled and released.
	Spiral Rolls not parallel to ironer	Keep spiral rolls parallel to the ironer at all times
	Aprons not tensioned properly	Adjust tension
	Guide roll covers worn/missing	Replace guide roll covers
	Apron drive roll bushings worn	Replace bushings

Section VI Illustrated Parts

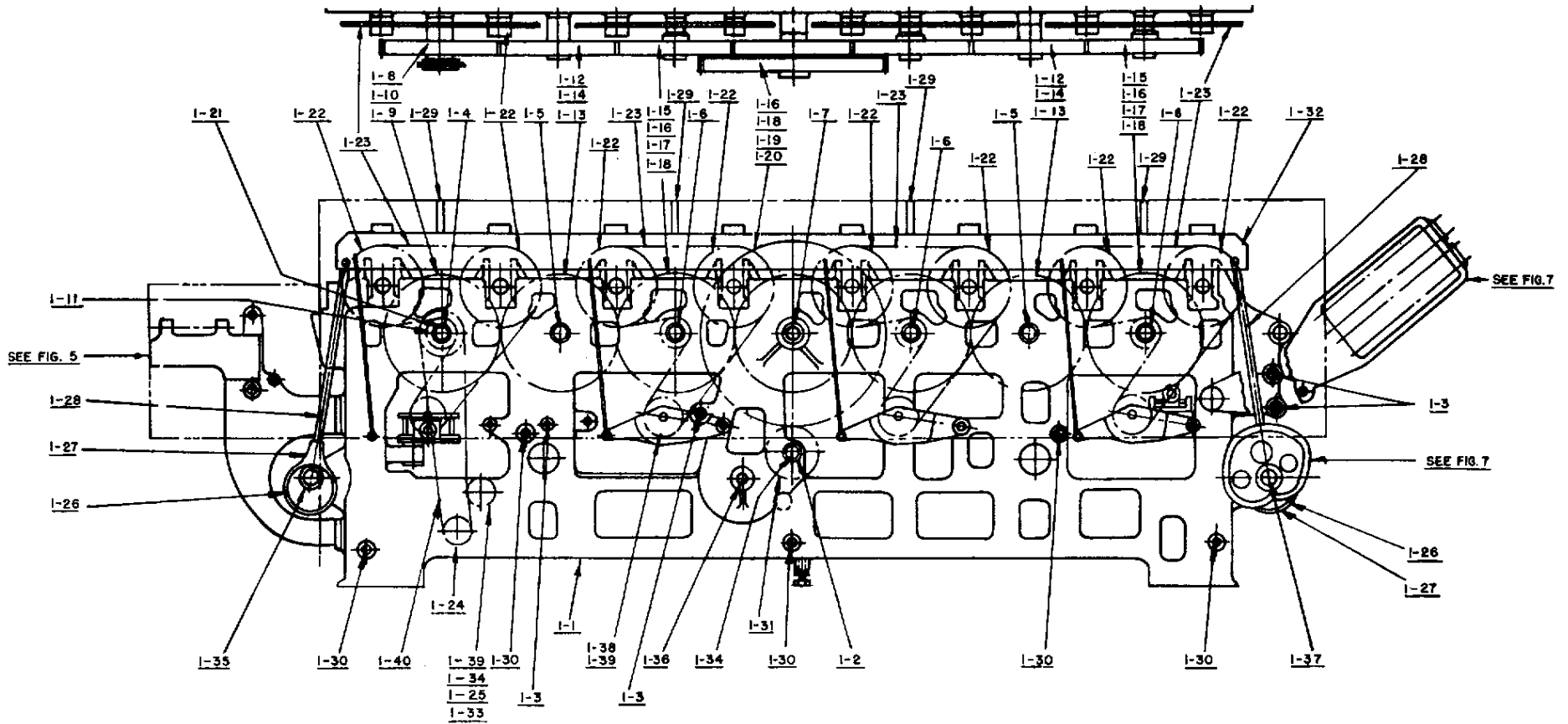

Illustration 1

Right Hand Outside Elevation

Drawing No.	Qty for 8 Roll	Part Number	Description	Remarks
1-1	1	IR-128-50	Right Hand Frame	
1-2	2	IR-3118-1055	Bushing for Main Drive Shaft on Drive Side (2 Required)	
1-3	8	IR-3116-1288	Idler Roll Bushing	
1-4	2	IR-3116-1299	Bushing, Intermediate Shaft	
Option	1	IR-118-42-A	Intermediate Shaft Conversion Kit	Used in place of IR-3116-1299
1-5	2	IR-128-626	Idler Stub Shaft for Needle Bearings 2" x 9 5/8"	
	2	IR-STUD-04	Idler Stub Shaft for Brass Bushings 1 15/16" x 9 5/8"	
1-6	3	IR-128-627	Drive Stub Shaft for Needle Bearings 2" x 10 5/8"	
	3	IR-STUD-05	Idler Stub Shaft for Brass Bushings 1 15/16" x 10 5/8"	
1-7	1	IR-126-66	Conversion Stub Shaft for Needle Bearings 2" x 12-5/8"	Must know actual length
	1	IR-128-628	Conversion Stub Shaft for Needle Bearings 2" x 11-5/8"	
	1	IR-128-627LONG	Conversion Stub Shaft for Needle Bearings 2" x 15 1/8"	
	1	IR-STUD-04	Idler Stub Shaft for Brass Bushings 1 15/16" x 11 5/8"	
1-8	1	IR-3118-0414	80th Gear w/24th Sprocket	
1-9	1	IR-GEAR-13	80TH Gear without 24 tooth Sprocket 1 15/16"	
1-10	1	IR-110-424	24T Sprocket	
1-11	1	IR-128-42	Intermediate Shaft Right Hand Side 12 Tooth Sprocket	
	1	IR-118-42-B	Intermediate Shaft Right Hand Side 12 Tooth Sprocket when Intermediate Shaft Conversion Kit is used	
1-12	2	IR-128-46	80TH Idler Gear with Needle Bearing	
	2	IR-GEAR-25	80TH Idler Gear with Brass Bushing	
1-13	Not available for purchase. Must use IR-128-46			
1-14	14	IR-C-16039	Needle Bearing for 80TH Gear	2 required per gear
	14	IR-3116-1339	Brass Bushing for 80 TH Gear	2 required per gear
1-15	3	IR-128-042	80TH gear with 12TH sprocket with Needle Bearing	
	3	IR-110-041	80TH gear with 12TH sprocket with Brass Bushing	
1-16	3	IR-3118-443	Gear, 80TH, 5P, 3-7/8" Bore with Keyway	
1-17	3	IR-128-444	12th Hub with Needle Bearing for IR-3118-443	
	3	IR-110-430	12th Hub with Brass Bushing for IR-3118-443	

Drawing No.	Qty for 8 Roll	Part Number	Description	Remarks
1-18	14	IR-C-16039	Needle Bearing for 80TH Gear	2 required per gear
	14	IR-3116-1339	Brass Bushing for 80 TH Gear	2 required per gear
1-19	1	Obsolete	216TH Herringbone with Hub	
1-20	1	Obsolete	216TH Herringbone	
1-21	1	IR-3118-6164	Intermediate Shaft for 120" Super Sylon	
1-22	8	IR-1382548	Padded Roll Sprocket, 34th/80#	
1-23	4	80-Chain	80 Chain cut to 92 Links	
1-24	1	IR-110-422	15TH 3/4P for Raising Rig	
1-25		Obsolete		
1-26	6	IR-110-130	Eccentric	
1-27	6	IR-110-131	Eccentric Strap	
1-28	6	IR-128-674	Eccentric Rod Coarse Thread	
1-29	6	IR-128-604	Pressure Bar guide Rod (Support Stud)	
1-30	6	Obsolete	Tie Rod	Must make to order
1-31	1	IR-3118-430	Herringbone Pinion	
1-32	2	IR-3118-05017	Pressure Bar	
1-33		Obsolete		
1-34	1	IR-3118-6121	Main Drive Shaft	Verify Type of Clutch
1-35	1	IR-128-602	Front Eccentric Shaft	Must make to order
1-36	1	IR-3118-6123	Center Eccentric Shaft	Must make to order
1-37	1	IR-3118-6165	Rear Eccentric Shaft	Must make to order
1-38	4	IR-1395789	15th Sprocket, 80# chain for Chain Bucket	
1-39	4	IR-110-636	Stud for Chain Bucket Sprocket	
1-40	1	60-Chain	60 Chain Cut to 92 Links	

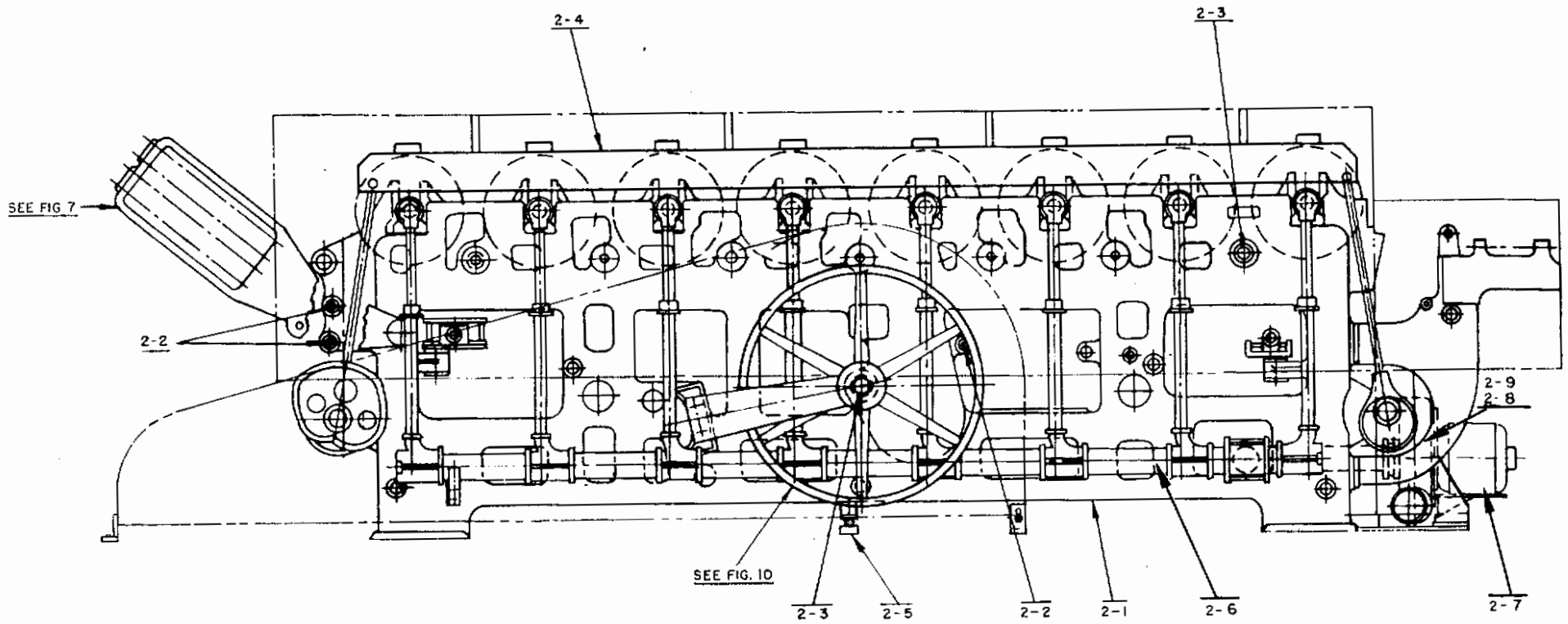

Illustration 2

Left Hand Outside Elevation

Drawing No.	Qty for 8 Roll	Part Number	Description	Remarks
2-1	1	IR-128-51	Left Hand Frame	
2-2	8	IR-3116-1288	Idler Roll Bushing	
2-3	2	IR-3116-1299	Bushing, Intermediate Shaft	
Option	1	IR-118-42-A	Intermediate Shaft Conversion Kit	Used in place of IR-3116-1299
2-4	2	IR-3118-05017	Pressure Bar	
2-5		Obsolete	Adjusting Bolt	

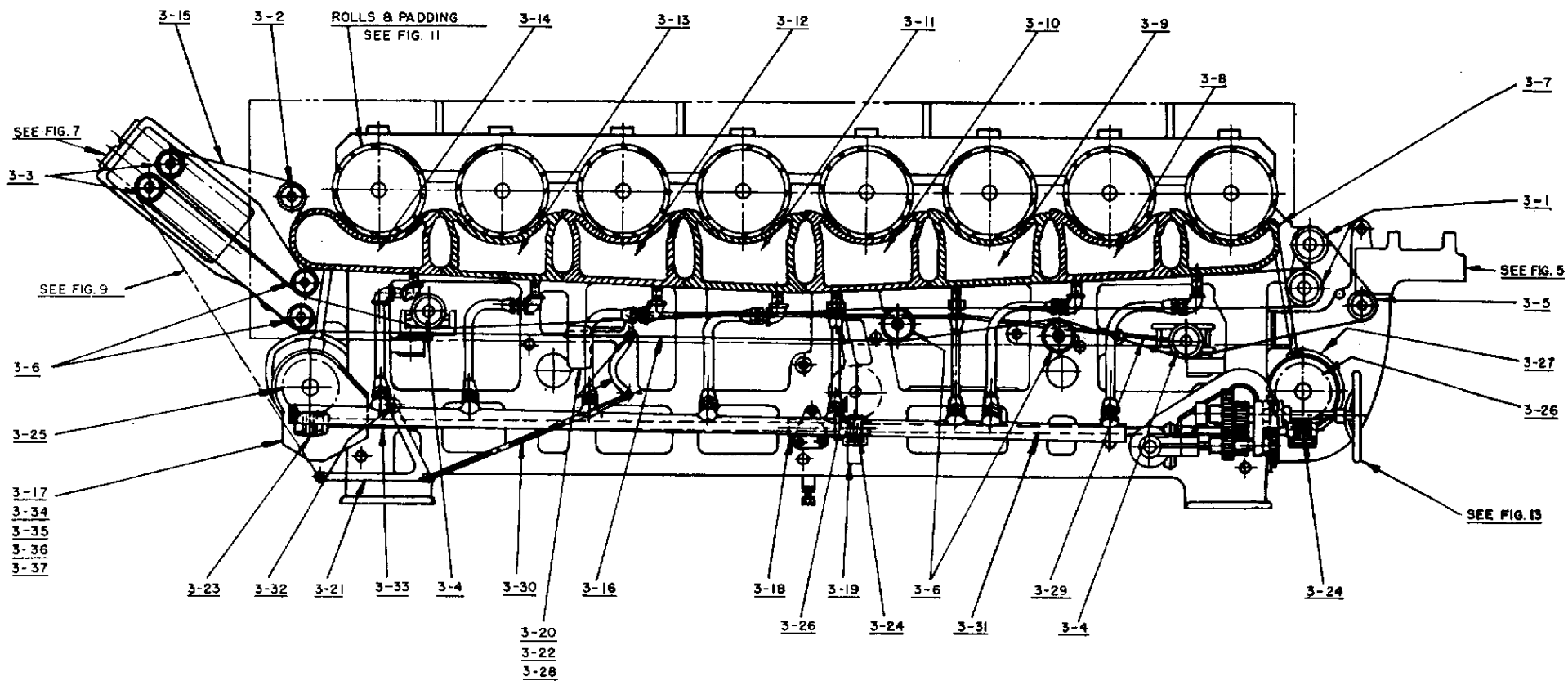

Illustration 3

Right Hand Inside Elevation

Rev 9/29/2015

Drawing No.	Qty for 8 Roll	Part Number	Description	Remarks
3-1	2	IR-110-082-5-120	Apron Drive Roll	
	2	IR-110-082-CONVERSION	Apron Drive Roll for C&W Conversions	
3-2	1	IR-110-086-3.5-120-A	Sort Spiral Roll	
3-3	2	IR-3118-0581-120-A	Spiral Roll	
3-4	2	IR-110-089-4.5-120	Apron Guide Roll	
3-5	1	IR-110-800-120	Front Apron Idler Roll	
3-6	4	IR-3116-0885-3-120	Apron Idler Roll	
3-7	1	Number 1 Chest	Must buy used	
3-8	1	Number 2 Chest	Must buy used	
3-9	1	Number 3 Chest	Must buy used	
3-10	1	Number 4 Chest	Must buy used	
3-11	1	Number 5 Chest	Must buy used	
3-12	1	Number 6 Chest	Must buy used	
3-13	1	Number 7 Chest	Must buy used	
3-14	1	Number 8 Chest	Must buy used	
3-15	1	Upper Apron	Purchased Through Tingue	
3-16	1	Lower Apron	Purchased Through Tingue	
3-17		Obsolete		
3-18		Obsolete		
3-19		Obsolete		
3-20	2	IR-116-20	Weight	
3-21	1	IR-3118-204	Bell Crank Rear Right Hand (Drive) Side	
3-22	2	IR-116-21	Center Bell Crank	
3-23	1	IR-110-40	Rear Worm	
3-24	2	IR-110-41	Front and Center Worm	
3-25	1	IR-110-43	Rear Worm Gear	
3-26	2	IR-110-421	Front/Center Worm Gears	
3-27		Obsolete		
3-28	1	IR-3118-635	Short Stud Counter Weight	
3-29	1	IR-118-627	Apron Guide Connecting Rod Right Side from Center Bell Crank to Movable Guide Box	

Drawing No.	Qty for 8 Roll	Part Number	Description	Remarks
3-30	1	IR-31140-61	Apron Guide Roll Connecting Rod from Rear Bell Crank to Center Bell Crank	
3-31		Obsolete		
3-32		Obsolete		
3-33		IR-128-0700	Steam Manifold Does Not Include any Hoses	
3-34		Obsolete		
3-35		Obsolete		
3-36		Obsolete		
3-37		Obsolete		

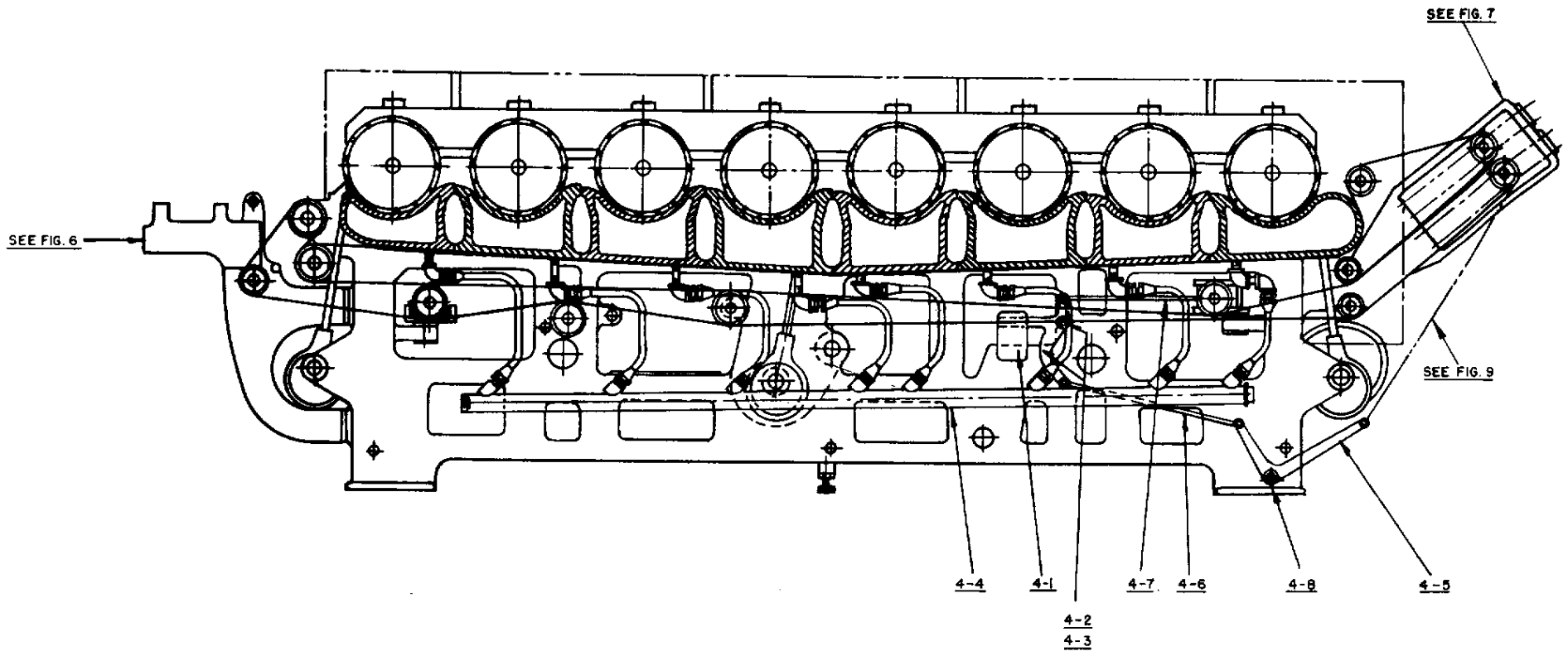

Illustration 4

Left Hand Inside Elevation

Rev 9/29/2015

Drawing No.	Qty for 8 Roll	Part Number	Description	Remarks
4-1	2	IR-116-20	Weight	
4-2	2	IR-116-21	Center Bell Crank	
4-3	1	IR-3118-635	Short Stud Counter Weight	
4-4	1	IR-128-0701	Steam Manifold Return L.H. Side Does Not Include Traps or Hoses	
4-5	1	IR-116-22	Bell Crank Rear Left Hand (Vacuum) Side	
4-6	1	IR-116-632	Short Connecting Rod From Left Rear Bell Crank to Center Bell Crank	
4-7	1	IR-116-630	Short Upper Connecting Rod From Center Bell Crank to Left Movable Guide Box	
4-8		Obsolete		

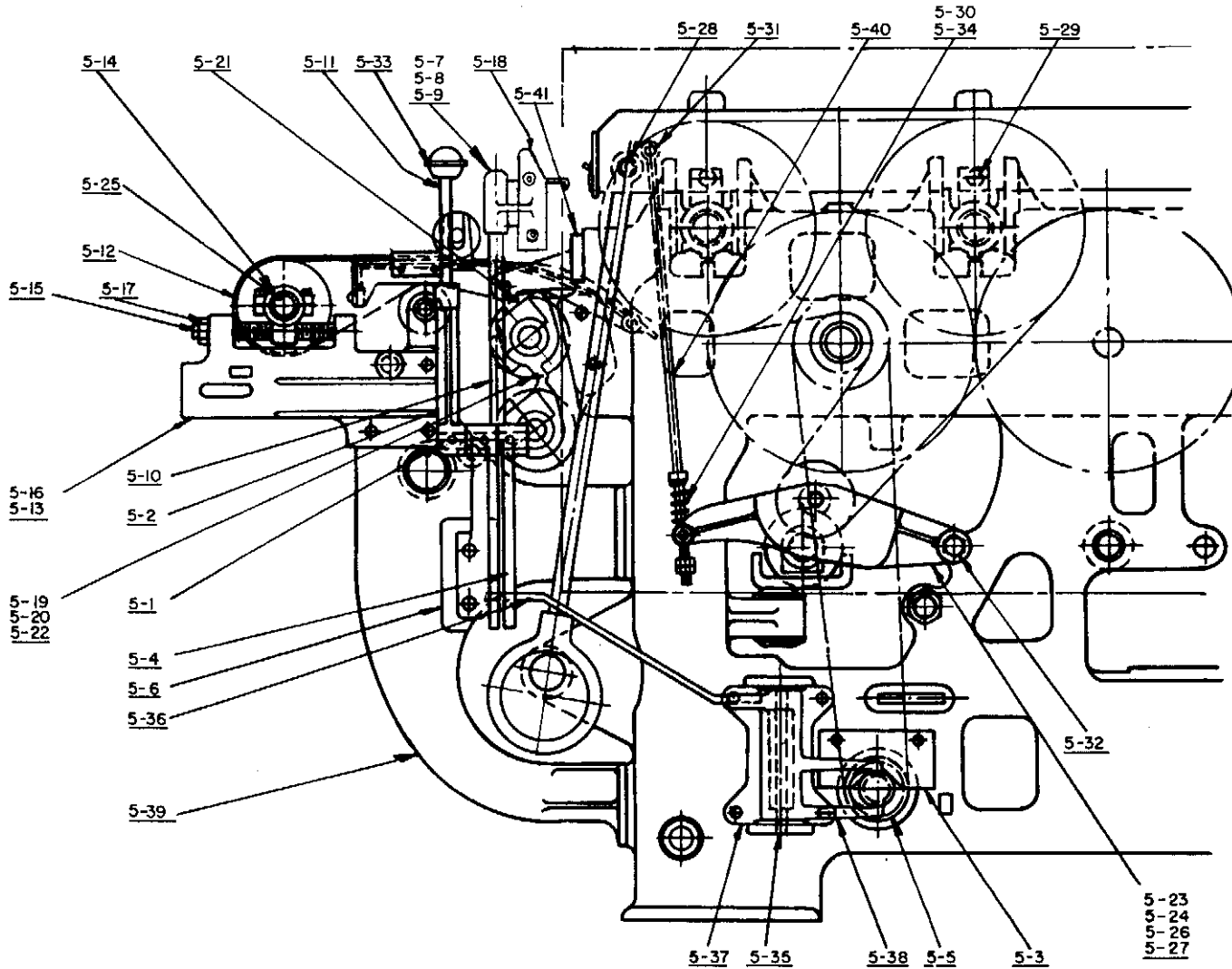

Illustration 5

Typical Right Hand Front End Side Elevation

Rev 9/29/2015

Drawing No.	Qty for 8 Roll	Part Number	Description	Remarks
5-1		Obsolete		
5-2		Obsolete		
5-3		Obsolete		
5-4		Obsolete		
5-5	1	IR-3116-1091	Shifter Spool Super Sylon/ Sylon/ Streamline	
5-6		Obsolete		
5-7	1	IR-128-0106	Safety Bar Bracket Right Side	
5-8		Obsolete		
5-9	1	IR-3116-1043	Coupling for Safety Rod	
5-10		Obsolete		
5-11		Obsolete		
5-12		Feed Belts	Sold by Tingue	
5-13		Obsolete		
5-14	2	IR-3116-01048	Feed Ribbon Roll Bracket	
5-15	2	IR-3116-6418	Feed Ribbon Bracket Shaft	
5-16		Obsolete		
5-17		Obsolete		
5-18	1	IR-128-639	Safety Board Assembly	
5-19	2	IR-118-102	OEM Apron Drive Roll Bracket	
	2	IR-118-102-CONVERSION	Apron Drive Roll Conversion Complete with Bearings	
5-20	4	IR-3118-1088	Apron Drive Roll Bushing for OEM Bracket	
	4	IR-118-102BRG	Flange Bearing for IR-118-102 Conversion	
5-21		Obsolete		
5-22	2	IR-118-102	OEM Apron Drive Roll Bracket	
5-23		Obsolete		
5-24	4	IR-118-20	Chain Bucket	
5-25	2	IR-3116-1329	Feed Roll Bushing	
5-26	4	IR-118-615	Swivel Knuckle	
5-27	4	IR-110-636	Stud for Chain Bucket Sprocket	
5-28	6	IR-31140-65	Large Pressure Bar Pin	
5-29	16	IR-3116-652	Roll Box Pin	

Drawing No.	Qty for 8 Roll	Part Number	Description	Remarks
5-30	4	IR-285-606	Chain Bucket Spring	
5-31	4	IR-118-620	Pressure Bar pin for Chain Bucket Rod	
5-32	4	IR-110-635	Bolt for Chain Bucket	
5-33		Obsolete		
5-34	4	IR-118-70	Chain Bucket Rod Spacer	
5-35		Obsolete		
5-36		Obsolete		
5-37		Obsolete		
5-38	1	IR-118-20	Clutch Shifter	
5-39		Obsolete		
5-40	4	IR-128-69	Chain Bucket Rod	
5-41	1	IR-128-14	R.H. Feed Board Bracket	

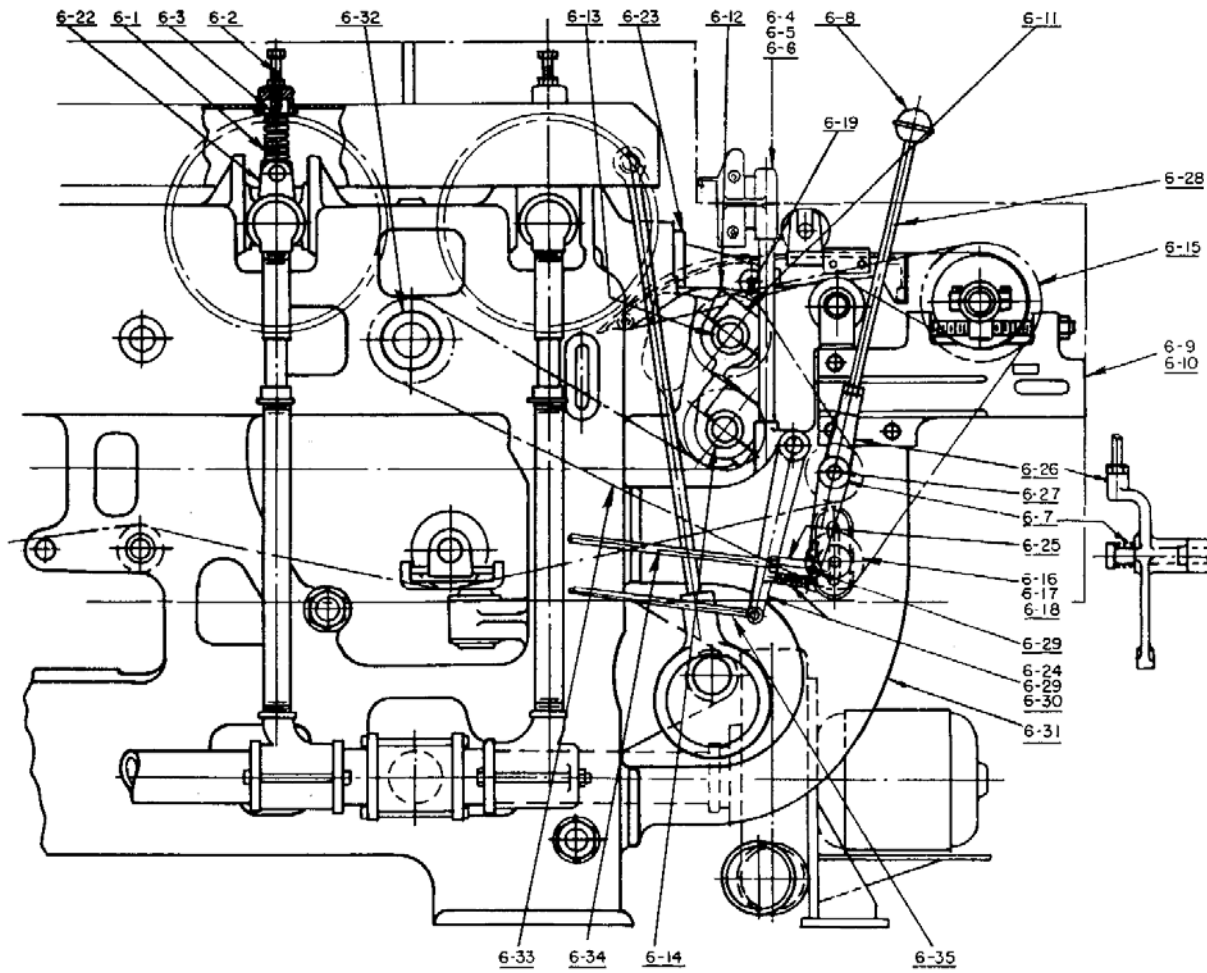

Illustration 6

Typical Left Hand Front End Side Elevation

Rev 9/29/2015

Drawing No.	Qty for 8 Roll	Part Number	Description	Remarks
6-1	16	IR-3118-657	Roll Box Pressure Spring	
6-2	16	IR-3116-6021	Bolt for Pressure Bar	
6-3	16	IR-3116-121	Roll Box Spring Cap	
6-4	1	IR-128-0107	Safety Bar Bracket L.H.	
6-5		Obsolete		
6-6	1	IR-3116-1043	Coupling for Safety Rod	
6-7		Obsolete		
6-8		Obsolete		
6-9		Obsolete		
6-10		Obsolete		
6-11		Obsolete		
6-12	2	IR-118-102	OEM Apron Drive Roll Bracket	
	2	IR-118-102-CONVERSION	Apron Drive Roll Conversion Complete with Bearings	
6-13	4	IR-3118-1088	Apron Drive Roll Bushing for OEM Bracket	
	4	IR-118-102BRG	Flange Bearing for IR-118-102 Conversion	
6-14	4	IR-3118-1088	Apron Drive Roll Bushing for OEM Bracket	
	4	IR-118-102BRG	Flange Bearing for IR-118-102 Conversion	
6-15	1	IR-Sprocket-21	32th Feed Roll Sprocket	
6-16	1	IR-3118-0419	15TH Idler Sprocket	
6-17		Obsolete		
6-18	1	IR-3118-6118	Feed Chain Idler Sprocket Stud	
6-19	2	IR-118-44	Apron Drive Roll, 31th/60# Sprocket	
6-20		Obsolete		
6-21		Obsolete		
6-22	16	IR-128-012-CI	Cast Iron Roll Box Assembly with Bushing	
	16	IR-128-012	Brass Roll Box	
6-23	1	IR-128-15	L.H. Feed Board Bracket	
6-24		Obsolete		
6-25		Obsolete		
6-26		Obsolete		
6-27		Obsolete		

Drawing No.	Qty for 8 Roll	Part Number	Description	Remarks
6-28		Obsolete		
6-29		Obsolete		
6-30		Obsolete		
6-31		Obsolete		
6-32	1	IR-128-47	20TH Intermediate Shaft Sprocket	
	1	IR-128-47-A	20TH Intermediate Shaft Sprocket for Intermediate Shaft Conversions	
6-33	1	60-Chain	60 Chain 148 Links	
6-34		Obsolete		
6-35		Obsolete		

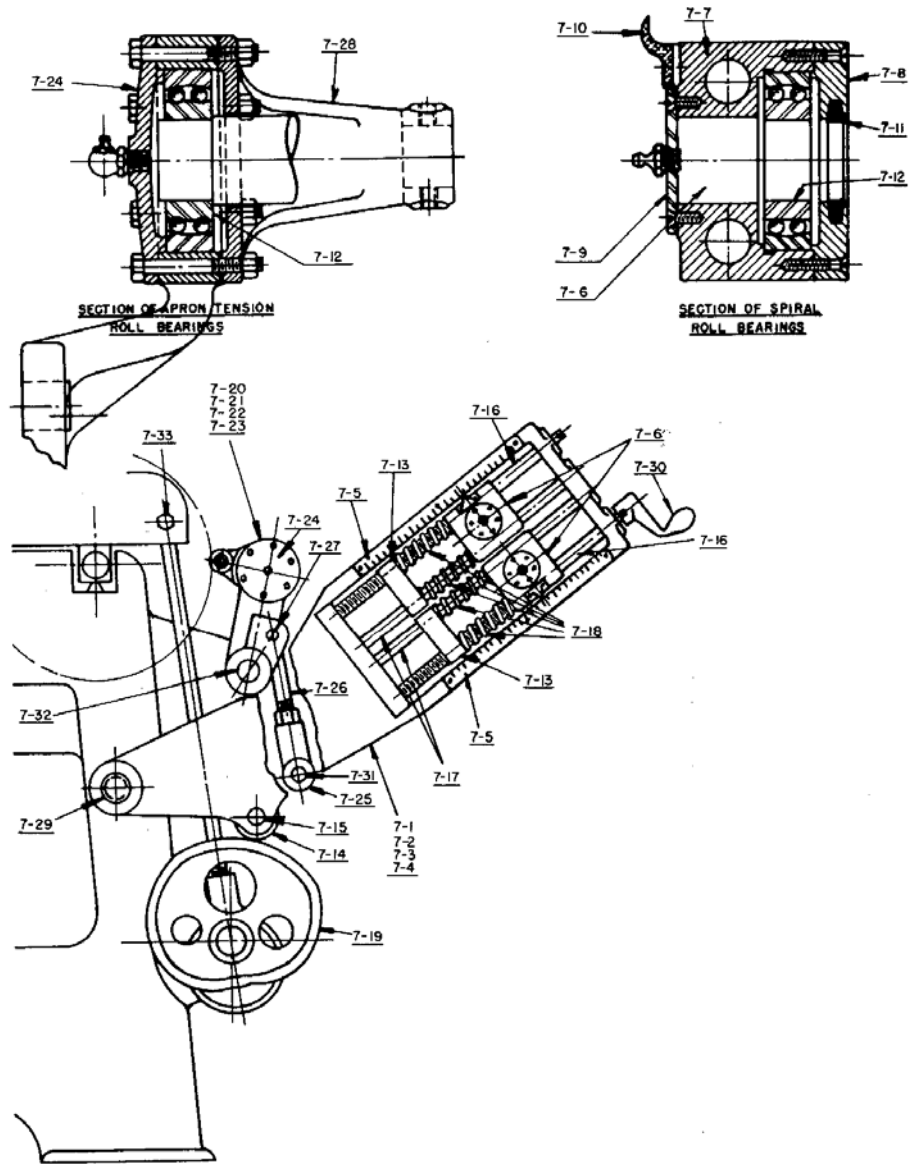

Illustration 7

Typical Right Hand Delivery End Side Elevation

Drawing No.	Qty for 8 Roll	Part Number	Description	Remarks
7-1		Obsolete		
7-2		Obsolete		
7-3		Obsolete		
7-4		Obsolete		
7-5		Obsolete		
7-6	4	IR-3118-0117	Bearing Housing Complete	
7-7	4	IR-3118-0115	Bearing Housing Only	
7-8	4	IR-3118-1016	Spiral Bearing Retainer	
7-9	4	IR-3118-1017	Cover Grease Cap for Spiral Roll Bearing	
7-10	4	IR-3116-1266	Pointer	
7-11		Obsolete		
7-12	6	IR-C-16055	Spiral Roll / Harp Bearings	
7-13	4	IR-3118-1019	Spring Support	
7-14	2	IR-3116-6164	Harp Cam Roller	
7-15	2	IR-3116-6165	Small Threaded Pin for Harp Roller	
7-16	4	IR-3118-6075	Screw Rod for Harps	
7-17	4	IR-3118-6076	Guide Rod for Harps	
7-18	8	IR-3118-6077	Spring for Harps	
7-19		Obsolete		
7-20		Obsolete		
7-21		Obsolete		
7-22	1	IR-118-22	Left Hand Lever	
7-23	1	IR-118-23	Right Hand Lever	
7-24	1	IR-3118-1021	Cover	
7-25		Obsolete		
7-26		Obsolete		
7-27		Obsolete		
7-28	2	IR-1378033	Tape Bar Brackets for 3/4" pipe	
7-29	2	IR-3116-651	Frame Pin for Harp	
7-30	4	IR-3118-202	Crank/Handle	
7-31	2	Obsolete		

Drawing No.	Qty for 8 Roll	Part Number	Description	Remarks
7-32	2	IR-118-626	Pivot Stud	
7-33	6	IR-31140-65	Large Pressure Bar Pin	

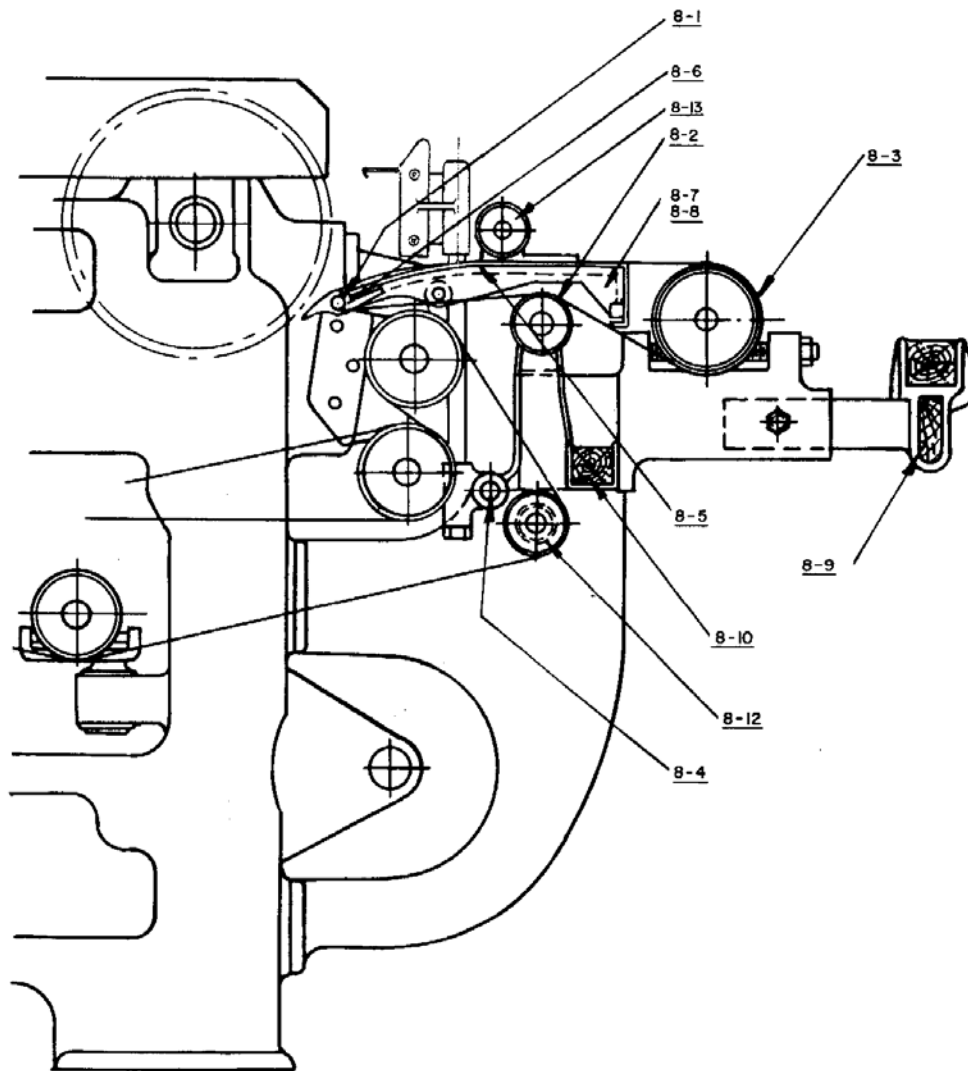

Illustration 8

Typical Inside Section Front End

Drawing No.	Qty for 8 Roll	Part Number	Description	Remarks
8-1	1	IR-3116-6541	Feed Board Finger Rod	
8-2	1	IR-31140-0848	Feed Ribbon Idler Roll	
8-3	1	HP-141-086-6-126	Feed Drive Roll	
8-4		Obsolete		
8-5	1	IR-128-0602	Feed Board Assembly	
8-6	46	IR-128-617	Feed Ribbon Guide Finger	
8-7		Obsolete		
8-8		Obsolete		
8-9		Obsolete		
8-10		Obsolete		
8-11		Obsolete		
8-12	2	IR-1391085	Front Apron Idler Roll Bushing	

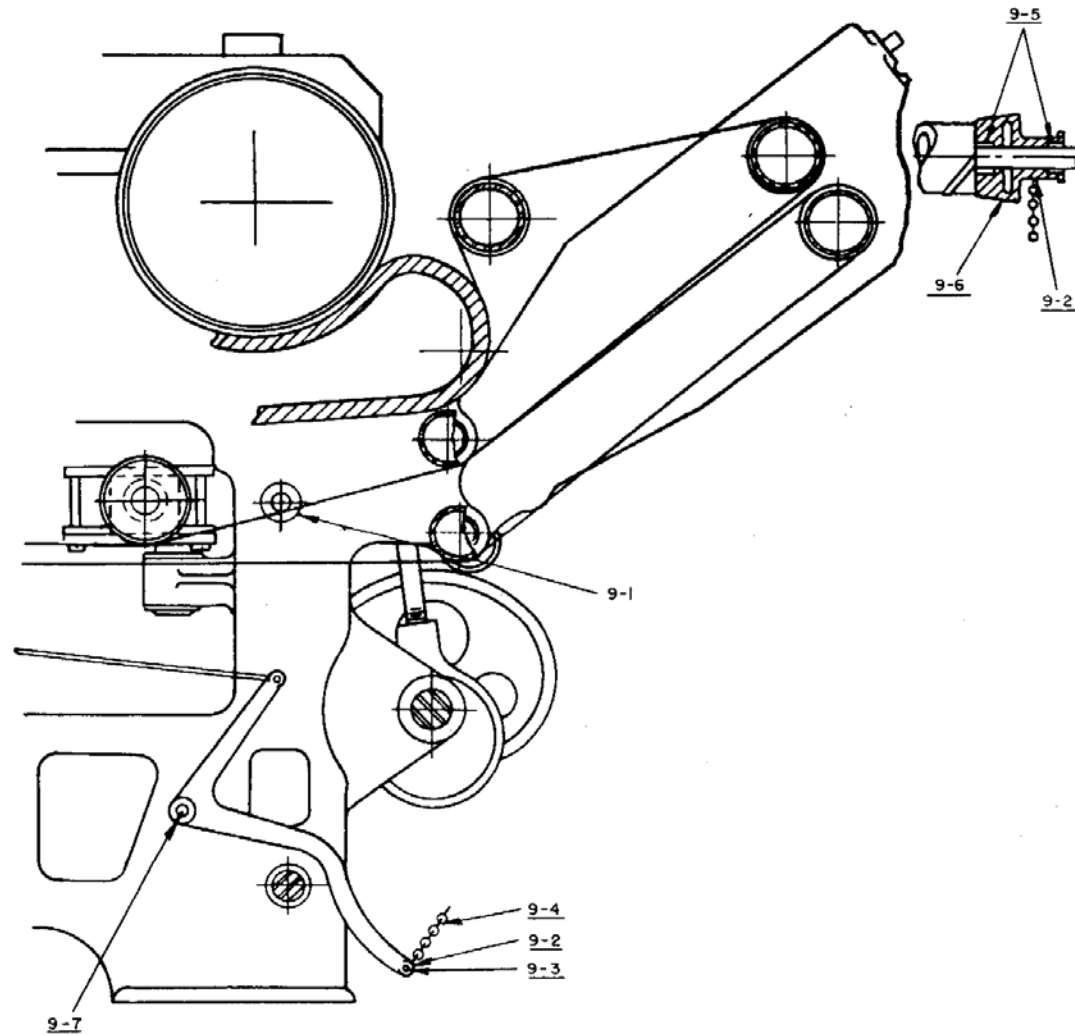

Illustration 9

Typical Inside Section Delivery End

Drawing No.	Qty for 8 Roll	Part Number	Description	Remarks
9-1	2	IR-3116-636	Washer, Spiral Roll Bracket Pin	
9-2		Obsolete		
9-3		Obsolete		
9-4		Obsolete		
9-5	160	IR-3118-6181	Cone Needle Bearings	
9-6	2	IR-1399062	Cone	
9-7	2	IR-31140-6079	Stud for Bell Crank Located On Center RH Rear	

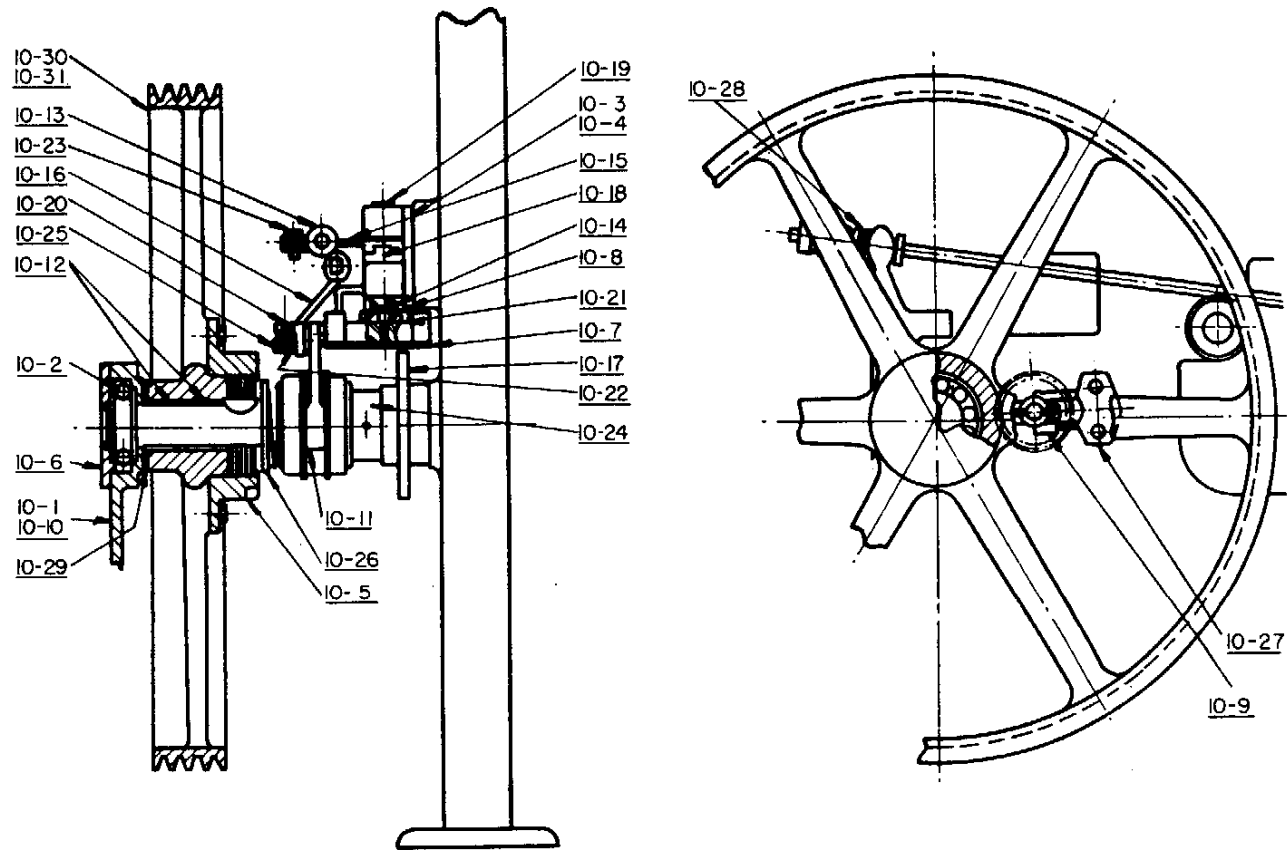

Illustration 10

Section of Clutch and Drive Sheave (NA Tingue Remanufactured Ironer)

Drawing No.	Qty for 8 Roll	Part Number	Description	Remarks
10-1		Obsolete		
10-2	1	IR-3118-0130	Clutch Arm Roller Bearing	
10-3		Obsolete		
10-4		Obsolete		
10-5		Obsolete		
10-6		Obsolete		
10-7		Obsolete		
10-8		Obsolete		
10-9		Obsolete		
10-10		Obsolete		
10-11		Obsolete		
10-12	1	IR-3116-1339	Bushing for Sheave 4, 6 & 8	
10-13	1	IR-118-23	Fork for Rod	
10-14		Obsolete		
10-15		Obsolete		
10-16		Obsolete		
10-17		Obsolete		
10-18		Obsolete		
10-19		Obsolete		
10-20	1	IR-3118-6035	Stud for Roller	
10-21		Obsolete		
10-22		Obsolete		
10-23		Obsolete		
10-24		Obsolete		
10-25	1	IR-3118-848	Roller Throw out Lever	
10-26		Obsolete		
10-27		Obsolete		
10-28		Obsolete		
10-29		Obsolete		
10-30		Obsolete		
10-31		Obsolete		

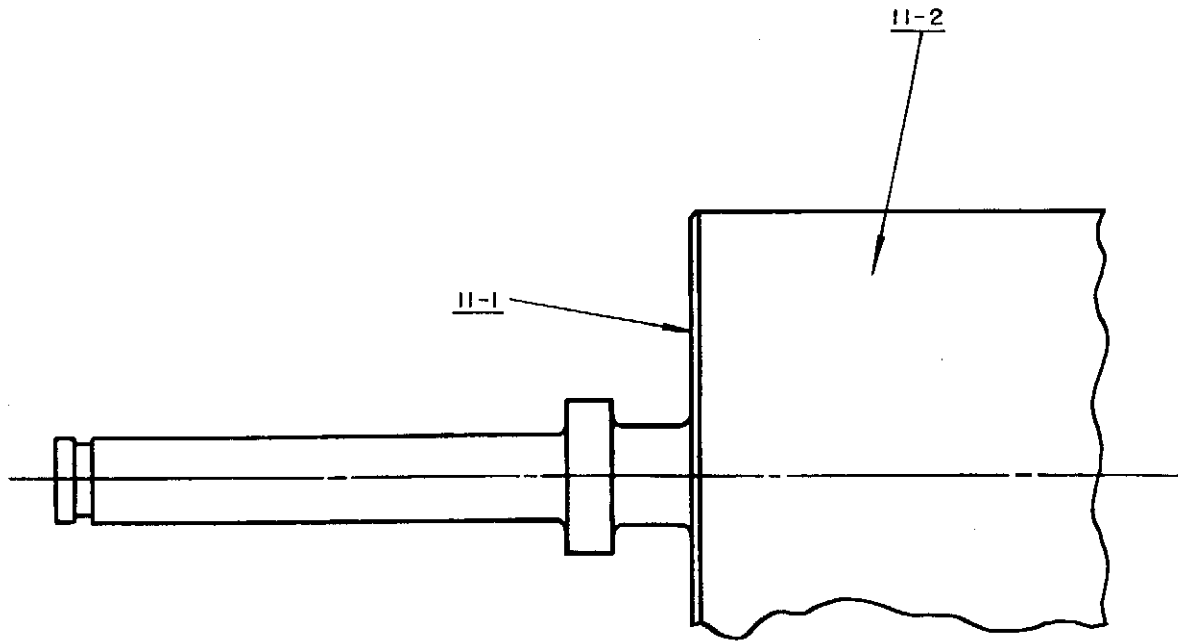

Illustration 11

Padded Roll

Drawing No.	Qty for 8 Roll	Part Number	Description	Remarks
11-1		Obsolete	Padded Roll	Available used Only
11-2		Springs, Pads and Covers	Various Options Available	See your Tingue Salesman to discuss the correct options for your ironer.

SECTION 12
INTENTIONALLY LEFT BLANK

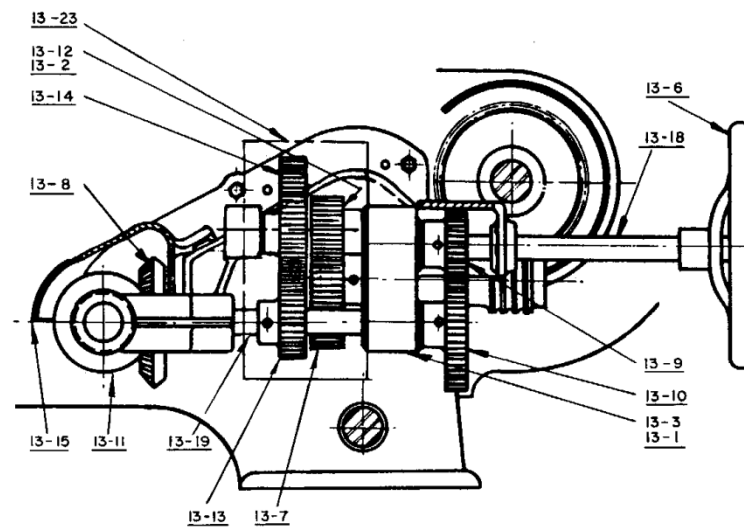
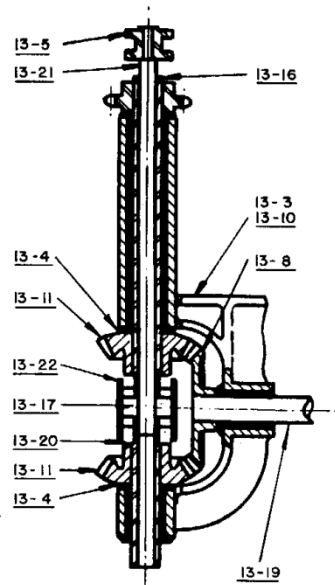

Illustration 13

Roll Raising Transmission

Drawing No.	Qty for 8 Roll	Part Number	Description	Remarks
13-1		Obsolete		Obsolete must by used
13-2		Obsolete		Obsolete must by used
13-3		Obsolete		Obsolete must by used
13-4		Obsolete		Obsolete must by used
13-5		Obsolete		Obsolete must by used
13-6		Obsolete		Obsolete must by used
13-7		Obsolete		Obsolete must by used
13-8		Obsolete		Obsolete must by used
13-9		Obsolete		Obsolete must by used
13-10		Obsolete		Obsolete must by used
13-11		Obsolete		Obsolete must by used
13-12		Obsolete		Obsolete must by used
13-13		Obsolete		Obsolete must by used
13-14		Obsolete		Obsolete must by used
13-15		Obsolete		Obsolete must by used
13-16		Obsolete		Obsolete must by used
13-17		Obsolete		Obsolete must by used
13-18		Obsolete		Obsolete must by used
13-19		Obsolete		Obsolete must by used
13-20		Obsolete		Obsolete must by used
13-21		Obsolete		Obsolete must by used
13-22		Obsolete		Obsolete must by used

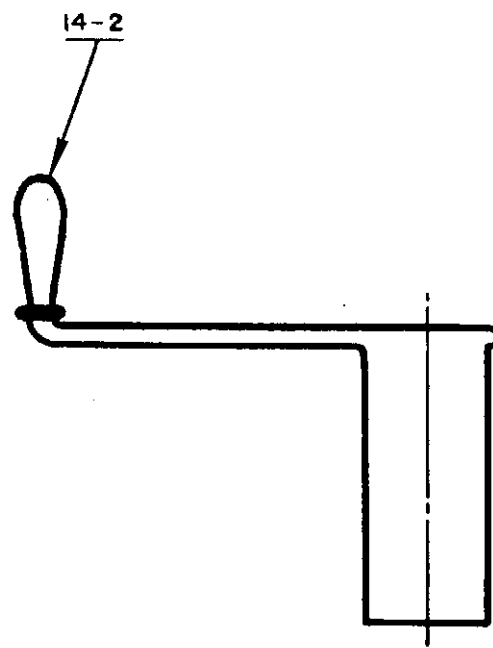
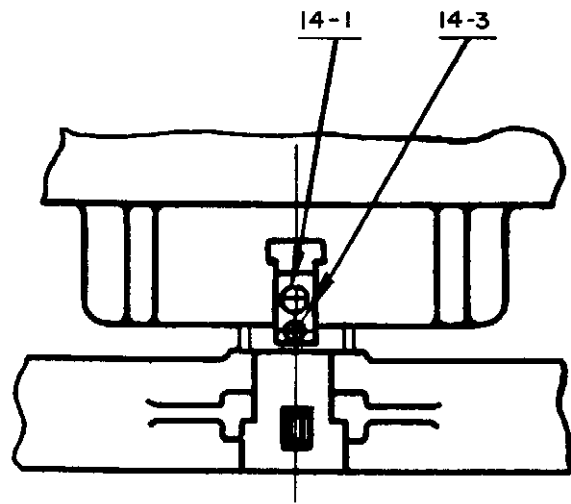

Illustration 14

Miscellaneous Parts

Drawing No.	Qty for 8 Roll	Part Number	Description	Remarks
14-1		Obsolete		
14-2	4	IR-3118-202	Hand Crank	
14-3		Obsolete		

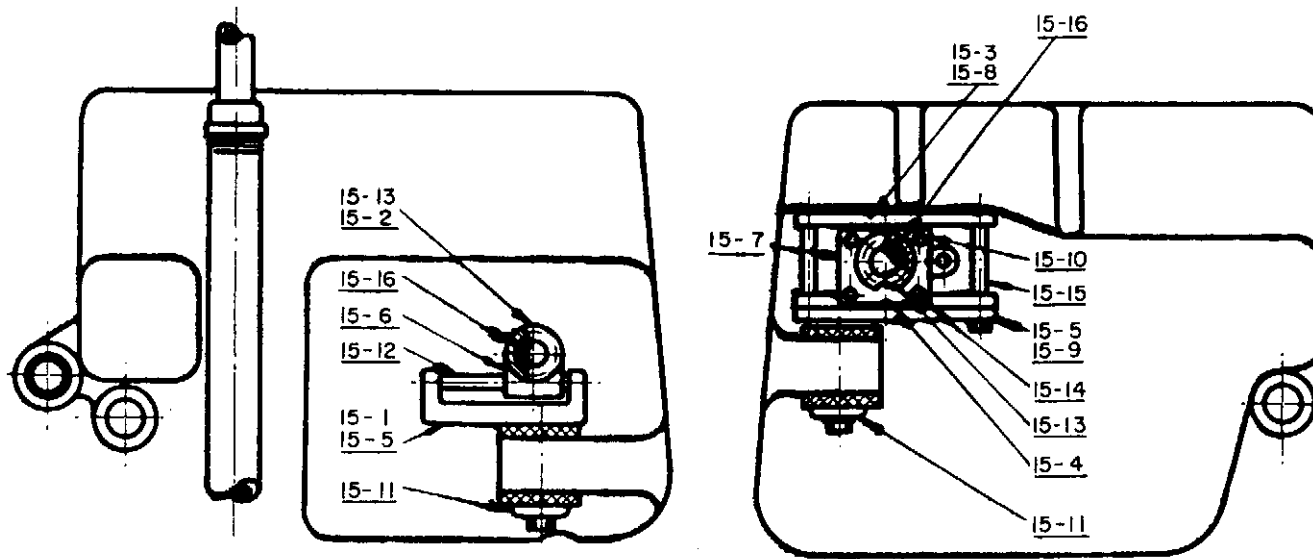

Illustration 15

Guide Roll Box Assemblies

Drawing No.	Qty for 8 Roll	Part Number	Description	Remarks
15-1		Obsolete		
15-2		Obsolete		
15-3	2	IR-3116-01025	Movable Guide Box Assembly	
15-4		Obsolete		
15-5		Obsolete		
15-6	2	IR-3116-1284	Stationary Guide Box	
15-7		Obsolete		
15-8	2	IR-3116-1286	Guide Bar	
15-9		Obsolete		
15-10	8	IR-3116-633	Roller, Apron Guide Box	
15-11	2	IR-3116-636	Washer	
15-12	2	IR-3116-6070	Shaft	
15-13	8	IR-3116-6364	Plate for Guide Assembly	
15-14	8	IR-3116-6365	Roller Pin	
15-15	4	IR-3116-6367	Guide Assembly Pin	
15-16	4	IR-Bearing-08	Guide Roll Guide Box Bearing & Sleeve	

SECTION 16
INTENTIONALLY LEFT BLANK

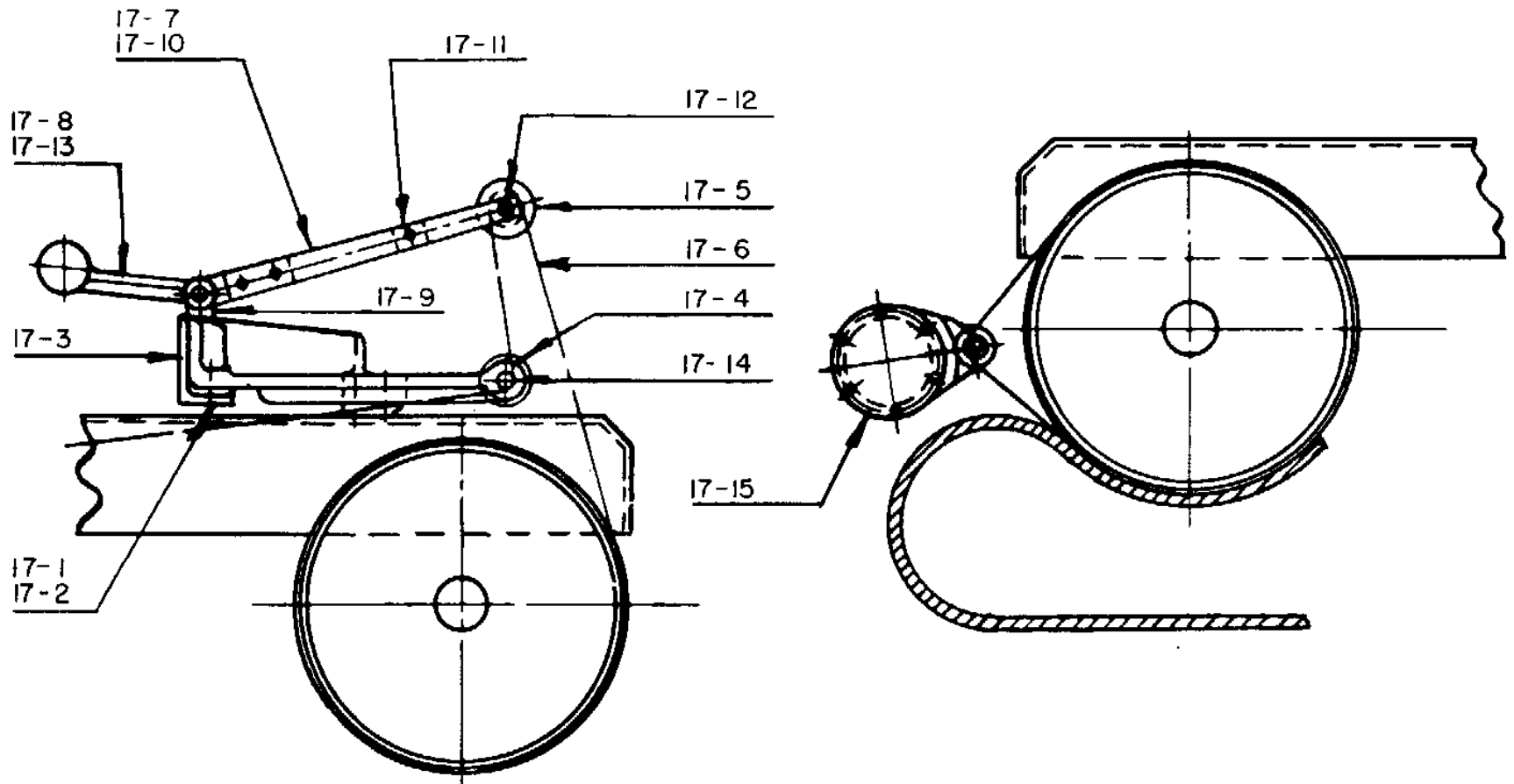

Illustration 17

Tape Device

Drawing No.	Qty for 8 Roll	Part Number	Description	Remarks
17-1	1	IR-3116-1338	Right Hand Bracket for Spool Arm Assembly	
17-2	1	IR-3116-1339	Left Hand Bracket for Spool Arm Assembly	
17-3	1	IR-126-600	Spool Arm Angel Iron Support	
17-4		Obsolete		
17-5	20	IR-1183235	Wool Tape Spools	
17-6		Tingue		
17-7	10	IR-126-010	Spool Arm Complete	
17-8	10	IR-126-11	Counter Weight	
17-9	10	IR-126-12	Holder/Support	
17-10	20	IR-126-13	Strip (Requires 2 per Spool Arm)	
17-11	40	IR-Collar-01	5/16 Collar	
17-12	10	IR-126-69	Stud for Spool Arm	
17-13	10	IR-609-621	Lower Pin for Spool Arm	
17-14	1	IR-126-065	Rod, Tape Spool	
17-15	2	IR-1378033	Brackets for 3/4" pipe	
17-16		Obsolete		
17-17		Obsolete		

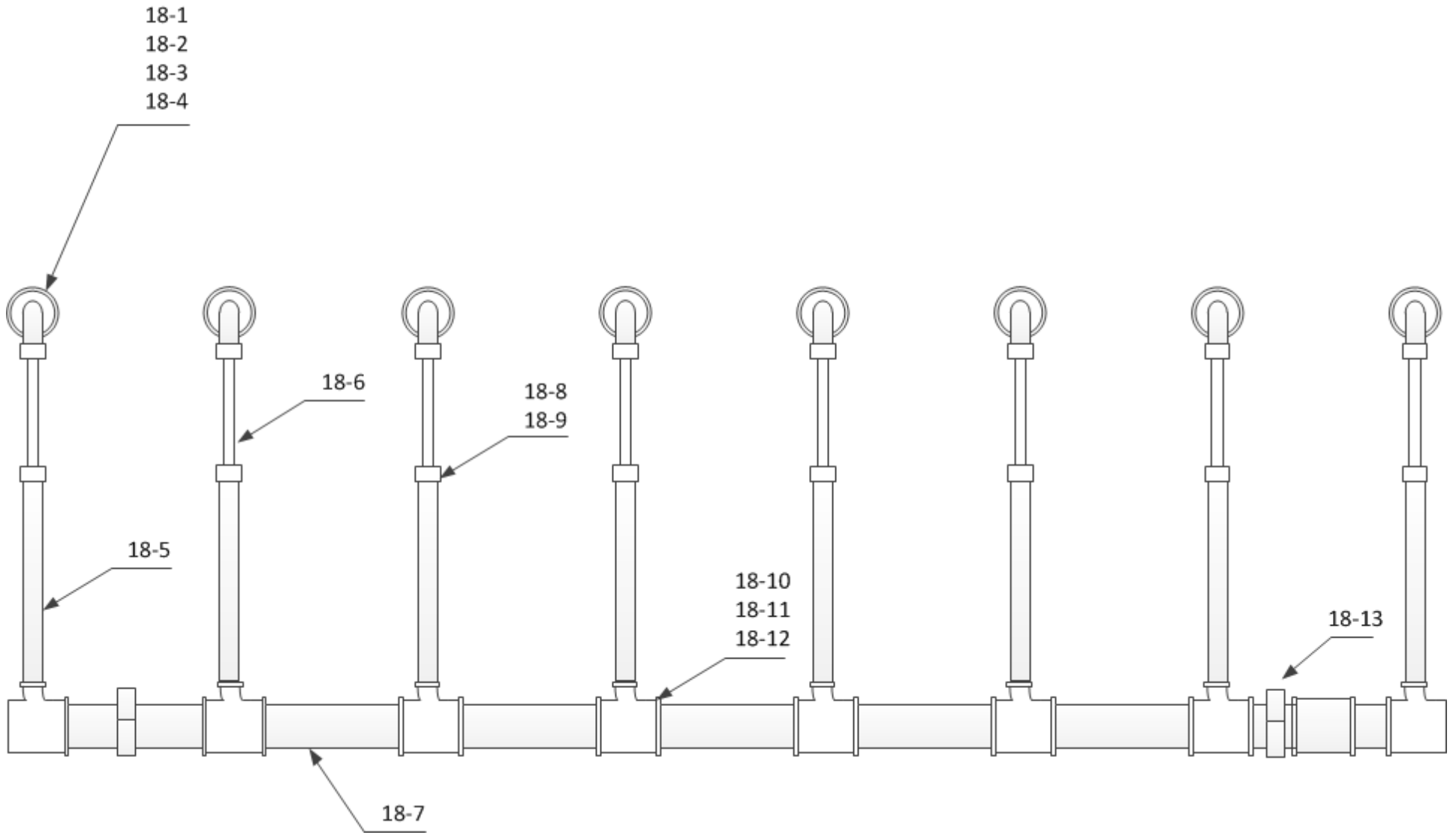

Illustration 17

Vacuum System

Drawing No.	Qty for 8 Roll	Part Number	Description	Remarks
18-1	8	IR-3116-730	Swing Joint Body	
18-2	8	IR-3116-731	Swing Joint Cover	
18-3	8	IR-3116-982	Vacuum Top Hat Packing	
18-4	8	IR-31140-73	Vacuum Split Ring	
18-5	8	IR-110-703	Lower Vacuum Pipe	
18-6	8	IR-31140-703	Upper Vacuum Pipe	
18-7	1	IR-126-070	Vacuum Manifold	
18-8	8	IR-31140-705	Vacuum Nut	
18-9	8	IR-31140-942	Graphite Packing	
18-10		Obsolete	Vacuum Tee	
18-11	16	IR-31140-941	Graphite Packing	
18-12	15	IR-31140-79	Clamp Ring	
18-13	4	IR-3118-1002	Manifold Bracket (2 per bracket)	
	1	IR-Blower	Blower	Not Shown

Section VI
Electrical Diagrams

Electrical Diagrams
for the
Tingue Right Hand Drive Conversions

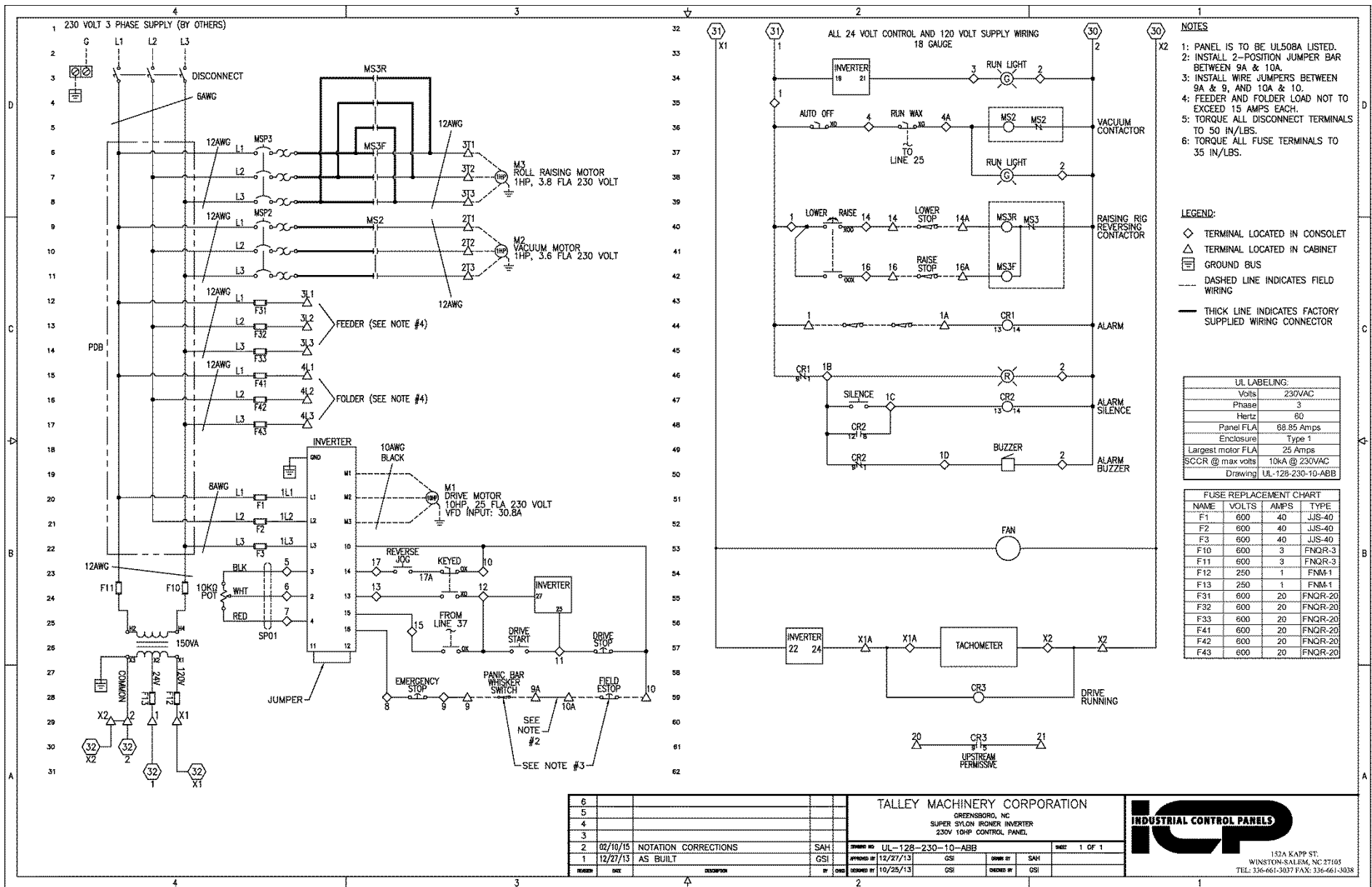

Illustration 19

230 Volt 10HP Right Hand Drive Conversion Electrical Diagram

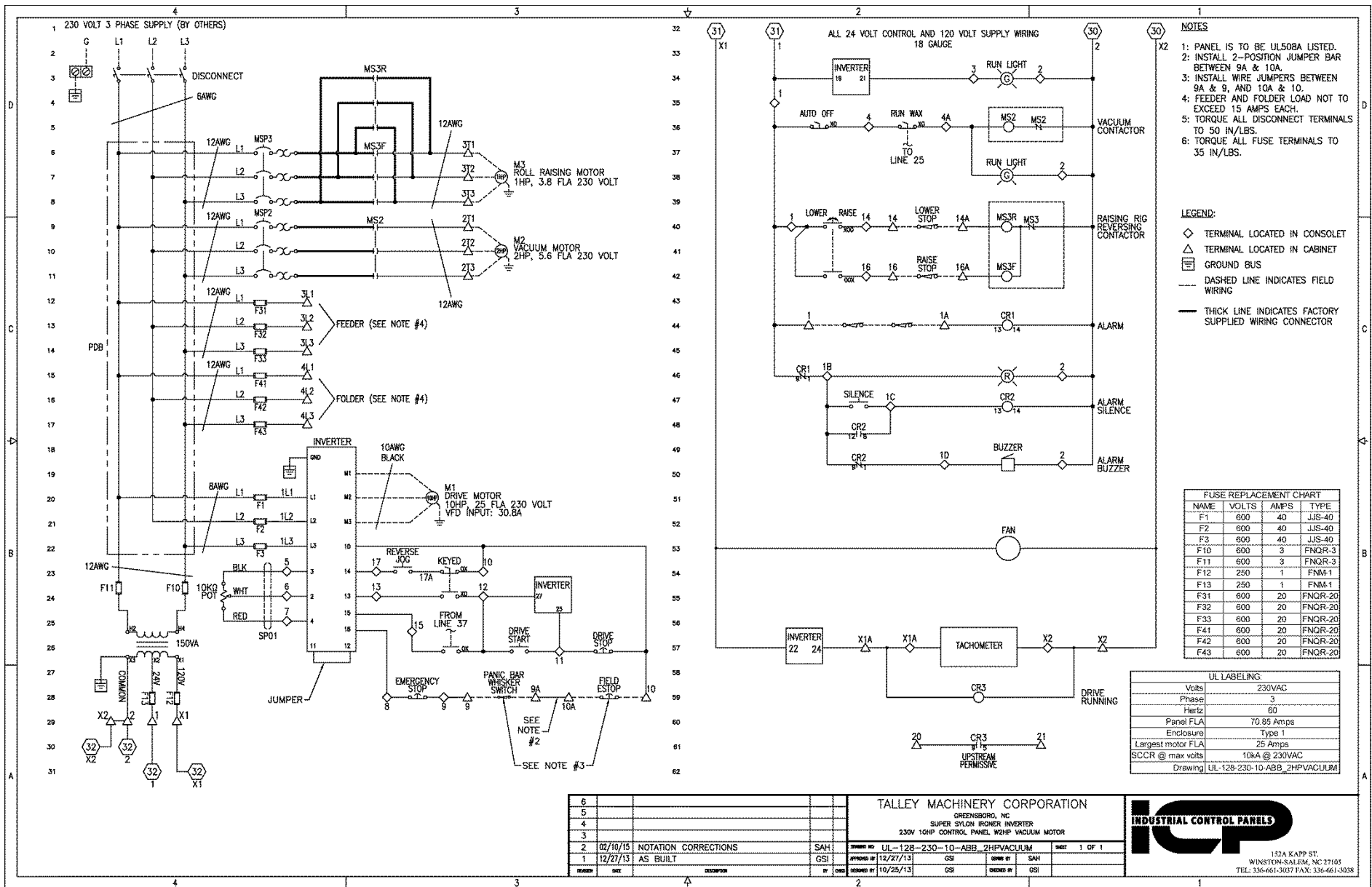

Illustration 20

230 Volt 10HP Right Hand Drive Conversion w/2HP Vacuum Electrical Diagram

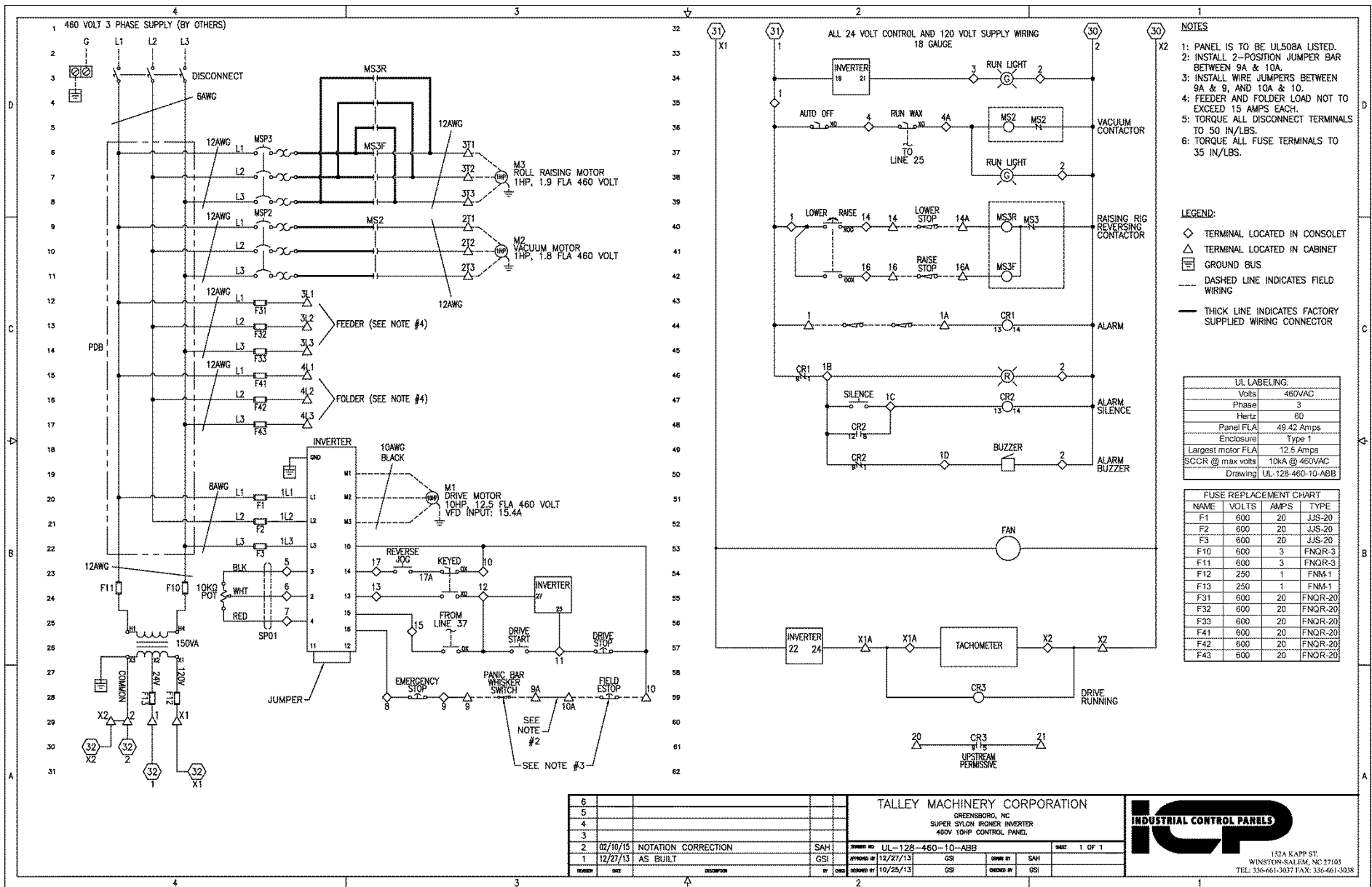

Illustration 21

460 Volt 10HP Right Hand Drive Conversion Electrical Diagram

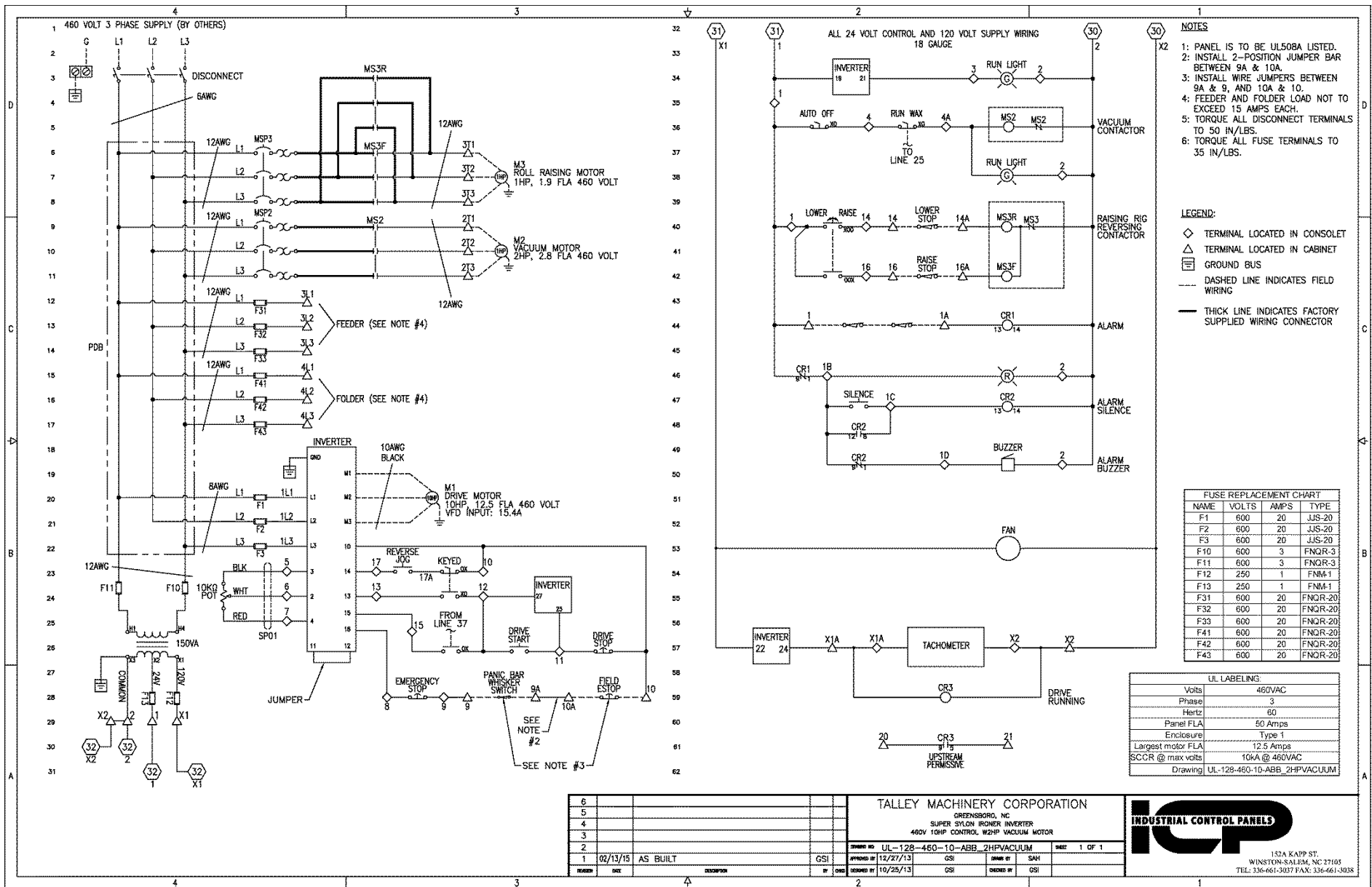

Illustration 22

460 Volt 10HP Right Hand Drive Conversion w/2HP Vacuum Electrical Diagram

Parameter Settings for ACS 550 Drive

Rev-5/29/2013

- 9901 - Language**
English (Am)
- 9902 – Application Macro**
ABB Standard
- 9904 - Motor Control Mode**
Vector Speed (must have motor hooked up) Use Scaler Frequency if motor not available.
- 9905 - Motor Nominal Voltage (See Nameplate Data)**
230 or 460
- 9906 - Motor Nominal Current (See Nameplate Data)**
- | HP | 230 Volt | 460 Volt |
|----|----------|----------|
| | 25 | 12.5 |
- 9907 - Motor Nominal Frequency**
60 Hz
- 9908 - Motor Nominal Speed –**
1760 RPM
- 9909 - Motor Nominal Horsepower**
10 HP
- 1001 – EXT1 Commands**
DI 1F,2R
- 1201 – Constant Speed Select**
DI3
- 1202 – Constant Speed 1**
450 RPM
- 1401 – Relay Output 1**
Run
- 1402 – Relay Output 2**
Started
- 1403 – Relay Output 3**
Started
- 2102 – Stop Function**
Ramp
- 2109 – Emergency Stop Selection**
DI6 (INV)
- 2203 – Deceleration Time 1**
3 sec.

Rev 9/29/2015